

ASUS[®] S-presso

Multimedia System

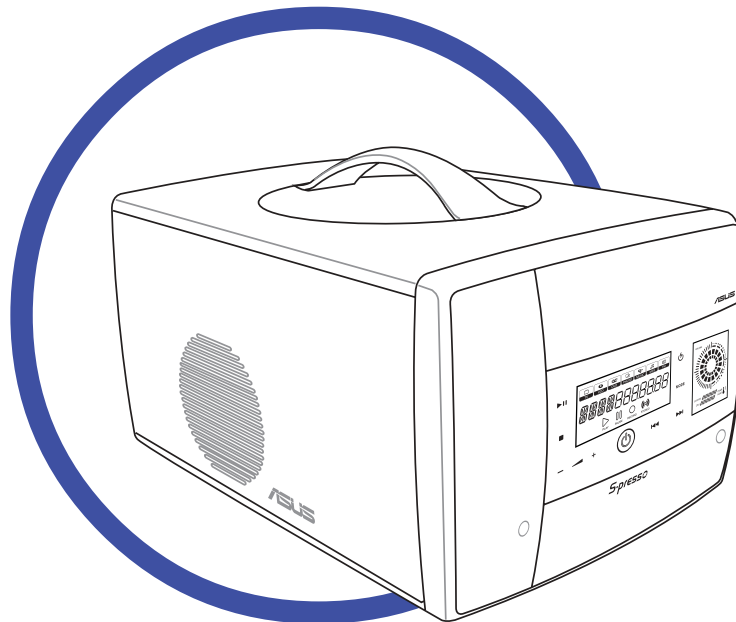

User Guide
Hardware Information

E1686

**First Edition V1
August 2004**

Copyright © 2004 ASUSTeK COMPUTER INC. All Rights Reserved.

No part of this manual, including the products and software described in it, may be reproduced, transmitted, transcribed, stored in a retrieval system, or translated into any language in any form or by any means, except documentation kept by the purchaser for backup purposes, without the express written permission of ASUSTeK COMPUTER INC. (“ASUS”).

Product warranty or service will not be extended if: (1) the product is repaired, modified or altered, unless such repair, modification or alteration is authorized in writing by ASUS; or (2) the serial number of the product is defaced or missing.

ASUS PROVIDES THIS MANUAL “AS IS” WITHOUT WARRANTY OF ANY KIND, EITHER EXPRESS OR IMPLIED, INCLUDING BUT NOT LIMITED TO THE IMPLIED WARRANTIES OR CONDITIONS OF MERCHANTABILITY OR FITNESS FOR A PARTICULAR PURPOSE. IN NO EVENT SHALL ASUS, ITS DIRECTORS, OFFICERS, EMPLOYEES OR AGENTS BE LIABLE FOR ANY INDIRECT, SPECIAL, INCIDENTAL, OR CONSEQUENTIAL DAMAGES (INCLUDING DAMAGES FOR LOSS OF PROFITS, LOSS OF BUSINESS, LOSS OF USE OR DATA, INTERRUPTION OF BUSINESS AND THE LIKE), EVEN IF ASUS HAS BEEN ADVISED OF THE POSSIBILITY OF SUCH DAMAGES ARISING FROM ANY DEFECT OR ERROR IN THIS MANUAL OR PRODUCT.

SPECIFICATIONS AND INFORMATION CONTAINED IN THIS MANUAL ARE FURNISHED FOR INFORMATIONAL USE ONLY, AND ARE SUBJECT TO CHANGE AT ANY TIME WITHOUT NOTICE, AND SHOULD NOT BE CONSTRUED AS A COMMITMENT BY ASUS. ASUS ASSUMES NO RESPONSIBILITY OR LIABILITY FOR ANY ERRORS OR INACCURACIES THAT MAY APPEAR IN THIS MANUAL, INCLUDING THE PRODUCTS AND SOFTWARE DESCRIBED IN IT.

Products and corporate names appearing in this manual may or may not be registered trademarks or copyrights of their respective companies, and are used only for identification or explanation and to the owners’ benefit, without intent to infringe.

Table of contents

Notices	vi
Safety information	vii
Electrical safety	vii
Operation safety	vii
About this guide	viii
System package contents	x

Chapter 1: System Introduction

1.1 Welcome!	1-2
1.2 Front panel (external)	1-2
1.3 Front panel (internal)	1-5
1.4 Rear panel	1-6
1.5 Internal components	1-8
1.6 LED panel	1-9

Chapter 2: Basic installation

2.1 Preparation	2-2
2.2 Before you proceed	2-2
2.3 Removing the front panel	2-3
2.4 Removing the cover	2-4
2.5 Removing the power supply unit	2-5
2.6 Installing a CPU	2-6
2.6.1 Removing the CPU fan and heatsink assembly	2-6
2.6.2 CPU installation	2-7
2.6.3 Re-installing the CPU fan and heatsink assembly	2-8
2.7 Installing a DIMM	2-9
2.7.1 Memory configurations	2-9
2.7.2 DIMM installation	2-10
2.8 Installing an expansion card	2-11
2.8.1 Expansion slots	2-11
2.8.2 Expansion card installation	2-12
2.8.3 Configuring an expansion card	2-13
2.9 Installing an optical drive	2-14
2.10 Installing a hard disk drive	2-16

Table of contents

2.11	Re-installing the power supply unit	2-17
2.11.1	Voltage selector	2-18
2.11.2	Power supply specifications	2-19
2.11	Replacing the cover	2-20
2.12	Connecting external devices	2-21

Chapter 3: Motherboard info

3.1	Introduction	3-2
3.2	Motherboard layout	3-2
3.3	Jumper	3-3
3.4	Connectors	3-4

Chapter 4: BIOS information

4.1	Managing and updating your BIOS	4-2
4.1.1	Creating a bootable floppy disk	4-2
4.1.2	Using AFUDOS to copy the current BIOS	4-3
4.1.3	Using AFUDOS to update the BIOS	4-4
4.1.4	Using ASUS EZ Flash to update the BIOS	4-6
4.1.5	Recovering the BIOS with CrashFree BIOS 2	4-7
4.1.6	ASUS Update	4-9
4.2	BIOS Setup program	4-11
4.2.1	BIOS menu screen	4-12
4.2.2	Menu bar	4-12
4.2.3	Navigation keys	4-12
4.2.4	Menu items	4-13
4.2.5	Sub-menu items	4-13
4.2.6	Configuration fields	4-13
4.2.7	Pop-up window	4-13
4.2.8	Scroll bar	4-13
4.2.9	General help	4-13
4.3	Main menu	4-14
4.3.1	System Time	4-14
4.3.2	System Date	4-14
4.3.3	Primary and Secondary IDE Master/Slave; Third and Fourth IDE Master	4-15

Table of contents

4.3.4	IDE Configuration	4-16
4.3.5	System Information	4-17
4.4	Advanced menu	4-18
4.4.1	CPU Configuration	4-18
4.4.2	Chipset	4-19
4.4.3	Onboard Devices Configuration	4-21
4.4.4	PCI PnP	4-23
4.4.5	USB Configuration	4-24
4.4.6	Load MiniLoader	4-25
4.5	Power menu	4-26
4.5.1	Suspend Mode	4-26
4.5.2	Repost Video on S3 Resume	4-26
4.5.3	ACPI 2.0 Support	4-26
4.5.4	ACPI APIC Support	4-26
4.5.5	APM Configuration	4-27
4.5.6	Hardware Monitor	4-28
4.6	Boot menu	4-29
4.6.1	Boot Device Priority	4-29
4.6.2	Removable Drives	4-30
4.6.3	Boot Settings Configuration	4-30
4.6.4	Security	4-32
4.7	Exit menu	4-34

Chapter 5: Starting up

5.2	Powering up	5-2
5.1	Installing an operating system	5-2
5.3	Support CD information	5-3
5.3.1	Running the support CD	5-3
5.3.2	Drivers menu	5-4
5.3.3	Utilities menu	5-5
5.3.4	ASUS contact information	5-6
5.3.5	Other information	5-6
5.4	Software information	5-8
5.4.1	ASUS Update	5-8
5.4.2	ASUS PC Probe	5-10
5.4.3	Multi-channel audio feature	5-14

Notices

Federal Communications Commission Statement

This device complies with Part 15 of the FCC Rules. Operation is subject to the following two conditions:

- This device may not cause harmful interference, and
- This device must accept any interference received including interference that may cause undesired operation.

This equipment has been tested and found to comply with the limits for a Class B digital device, pursuant to Part 15 of the FCC Rules. These limits are designed to provide reasonable protection against harmful interference in a residential installation. This equipment generates, uses and can radiate radio frequency energy and, if not installed and used in accordance with manufacturer's instructions, may cause harmful interference to radio communications. However, there is no guarantee that interference will not occur in a particular installation. If this equipment does cause harmful interference to radio or television reception, which can be determined by turning the equipment off and on, the user is encouraged to try to correct the interference by one or more of the following measures:

- Reorient or relocate the receiving antenna.
- Increase the separation between the equipment and receiver.
- Connect the equipment to an outlet on a circuit different from that to which the receiver is connected.
- Consult the dealer or an experienced radio/TV technician for help.



The use of shielded cables for connection of the monitor to the graphics card is required to assure compliance with FCC regulations. Changes or modifications to this unit not expressly approved by the party responsible for compliance could void the user's authority to operate this equipment.

Canadian Department of Communications Statement

This digital apparatus does not exceed the Class B limits for radio noise emissions from digital apparatus set out in the Radio Interference Regulations of the Canadian Department of Communications.

This class B digital apparatus complies with Canadian ICES-003.

Safety information

Electrical safety

- To prevent electrical shock hazard, disconnect the power cable from the electrical outlet before relocating the system.
- When adding or removing devices to or from the system, ensure that the power cables for the devices are unplugged before the signal cables are connected.
- If the power supply is broken, do not try to fix it by yourself. Contact a qualified service technician or your retailer.

Operation safety

- Before installing devices into the system, carefully read all the documentation that came with the package.
- Before using the product, make sure all cables are correctly connected and the power cables are not damaged. If you detect any damage, contact your dealer immediately.
- To avoid short circuits, keep paper clips, screws, and staples away from connectors, slots, sockets and circuitry.
- Avoid dust, humidity, and temperature extremes. Do not place the product in any area where it may become wet. Place the product on a stable surface.
- If you encounter technical problems with the product, contact a qualified service technician or your retailer.

Lithium-Ion Battery Warning

CAUTION: Danger of explosion if battery is incorrectly replaced. Replace only with the same or equivalent type recommended by the manufacturer. Dispose of used batteries according to the manufacturer's instructions.

VORSICHT: Explosionsgefahr bei unsachgemäßen Austausch der Batterie. Ersatz nur durch denselben oder einem vom Hersteller empfohlenem ähnlichen Typ. Entsorgung gebrauchter Batterien nach Angaben des Herstellers.

LASER PRODUCT WARNING

CLASS 1 LASER PRODUCT

About this guide

Audience

This guide provides general information and installation instructions about the ASUS S-presso. This guide is intended for experienced users and integrators with hardware knowledge of personal computers.

How this guide is organized

1. Chapter 1: System Introduction

This chapter gives a general description of the ASUS S-presso. The chapter lists the system features including introduction on the front and rear panels, and internal components.

2. Chapter 2: Basic Installation

This chapter provides step-by-step instructions on how to install components in the ASUS S-presso system.

3. Chapter 3: Motherboard Information

This chapter gives information about the P4P8T motherboard that comes with the system. This chapter includes the motherboard layout, jumper settings, and connector locations.

4. Chapter 4: BIOS Information

This chapter tells how to change system settings through the BIOS Setup menus and describes the BIOS parameters.

5. Chapter 5: Starting Up

This chapter helps you power up the system and install drivers and utilities from the support CD.

Conventions used in this guide



WARNING: Information to prevent injury to yourself when trying to complete a task.



CAUTION: Information to prevent damage to the components when trying to complete a task.



IMPORTANT: Information that you **MUST** follow to complete a task.



NOTE: Tips and additional information to aid in completing a task.

Where to find more information

Refer to the following sources for additional information and for product and software updates.

1. ASUS websites

The ASUS websites worldwide provide updated information on ASUS hardware and software products. Refer to the ASUS contact information.

2. Optional documentation

Your product package may include optional documentation, such as warranty flyers, that may have been added by your dealer. These documents are not part of the standard package.

System package contents

Check your ASUS S-presso package for the following items.

Item Description	S-presso Models	
	S1-P111	S1-P112
1. ASUS S-presso barebone system with		
• ASUS P4P8T motherboard	✓	✓
• LED panel	✓	X
• 7-in-1 storage card reader	✓	✓
• CPU fan and heatsink assembly	✓	✓
2. Cables		
• AC power cable	✓	✓
• Serial ATA cable	✓	✓
• IDE cables	✓	✓
3. CDs		
• Support CD	✓	✓
• ASUS Instant On CD	✓	X
• ASUS Home Theater CD	✓	X
4. Documentation		
• User guide (Hardware Information)	✓	✓
• User guide (Software Information)	✓	X
5. Remote controller	✓	X
6. Power supply unit	✓	✓
7. Optional items		
• Optical drive		
• Hard disk drive		
• ASUS PVR-416 TV/FM card		



If any of the above items is damaged or missing, contact your retailer immediately.

Chapter 1

This chapter gives a general description of the ASUS S-presso. The chapter lists the system features including introduction on the front and rear panels, and internal components.

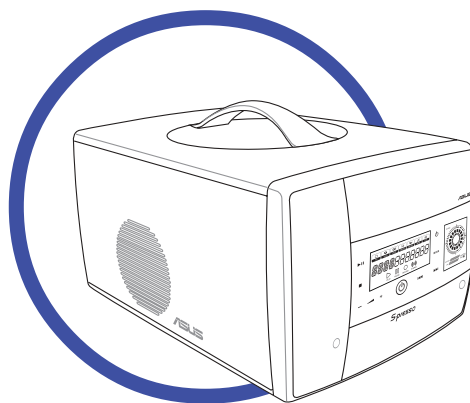

ASUS S-presso barebone system

System Introduction

1.1 Welcome!

Thank you for choosing the ASUS S-presso Multimedia System!

Now you can experience the quality entertainment of consumer electronics right on your own desktop. The ASUS S-presso is a smart personal computer and a versatile home entertainment system in one. Powered by the ASUS P4P8T motherboard, S-presso delivers robust technology for your computing and multimedia entertainment needs.

S-presso supports the Intel® Pentium® 4 processor with up to 3.4 GHz core frequency and up to 2 GB of system memory. Connect external devices and peripherals with USB 2.0 ports, a fast Ethernet LAN port, audio ports, and an S/PDIF Out interface.

The S-presso S1-P111 model allows effortless control at the touch of your fingertips with its touch sensor control panel and LED display. The S-presso S1-P111 also features Instant ON, which allows you to enjoy DVD/DVD movies and stereo quality CD/MP3 audio without entering the S-presso operating system.

1.2 Front panel (external)

The S-presso front panel includes the system buttons and audio/video touch sensors, system LEDs, and LED panel. The front panel doors give you access to the 4-slot card reader, audio ports, and USB ports.



The touch sensors are available only on the S1-P111 model.

S1-P112

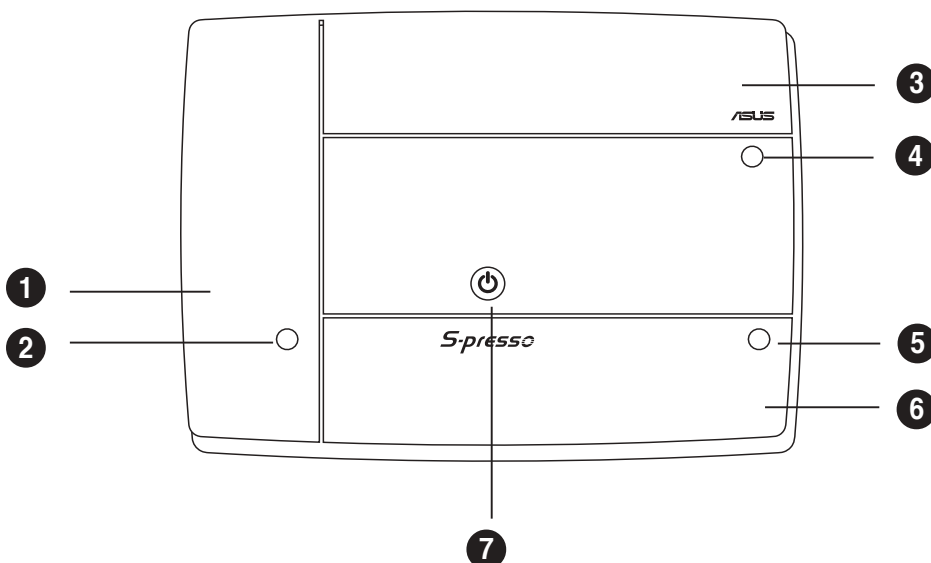

S1-P111

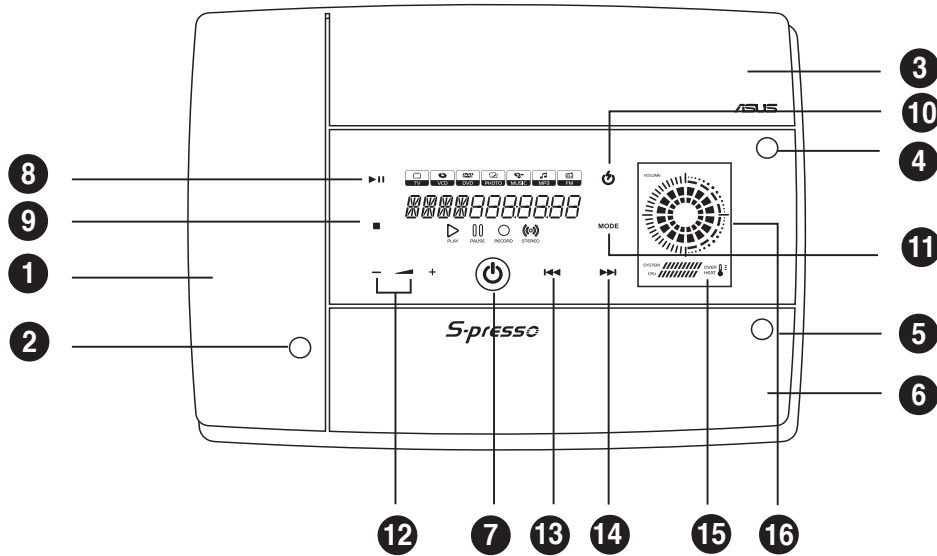

The touch sensors are sensitive. Slightly touch the function you want to enable. Do not press the front panel too hard to prevent damage to the panel and the sensors.

1. **Card slots door.** The storage card slots are located inside this door.
2. **Card slots door access button.** Press this button to open the card panel door.
3. **Optical drive door.** The optical drive that comes with your S-presso system is located inside this door.
4. **Optical drive tray eject button.** Press this button to eject the optical drive tray.
5. **Front panel I/O door access button.** Press this button to open the front panel I/O door.
6. **Front panel I/O door.** Inside this door are the front panel input/output ports.
7. **System power button.** Press this button to exit Instant On. The system then powers on and enters the S-presso operating system.
8. **PLAY/PAUSE sensor.** Plays the audio CD/DVD or DVD/VCD in the optical drive.

When playing an audio track, it pauses the track being played.

During movie playback, it pauses the movie.

9. **STOP sensor.** Touch this sensor to stop the audio track/file being played.
10. **Instant On POWER sensor.** Touch this sensor to turn on the S-presso Instant On feature. The Instant On feature allows you to play DVD/VCD movie, CD audio tracks, or MP3 files without entering the S-presso operating system.
11. **MODE SWITCH sensor.** Touch this sensor to switch from one mode to another.
12. **SYSTEM VOLUME CONTROL sensor.** Touch the (+) sensor to increase the system volume or the (-) to decrease the system volume.
13. **REWIND sensor.** Touch this sensor to rewind the audio track/movie.
14. **FORWARD sensor.** Touch this sensor to play the audio track/movie in fast forward mode.
15. **System/CPU temperature LED.** This LED displays the temperature status of the system and the CPU. Green means the temperature is within normal range. As temperature increases, the LED position goes towards the red area. The **Overheat** LED lights up when the system/CPU temperature is beyond normal range.
16. **Volume LED.** Rotating LED displays indicate the increase or decrease in system volume.

1.3 Front panel (internal)

The storage card slots and several I/O ports are located inside the internal front panel doors. Press the access buttons to open the internal front panel doors.

S1-P111

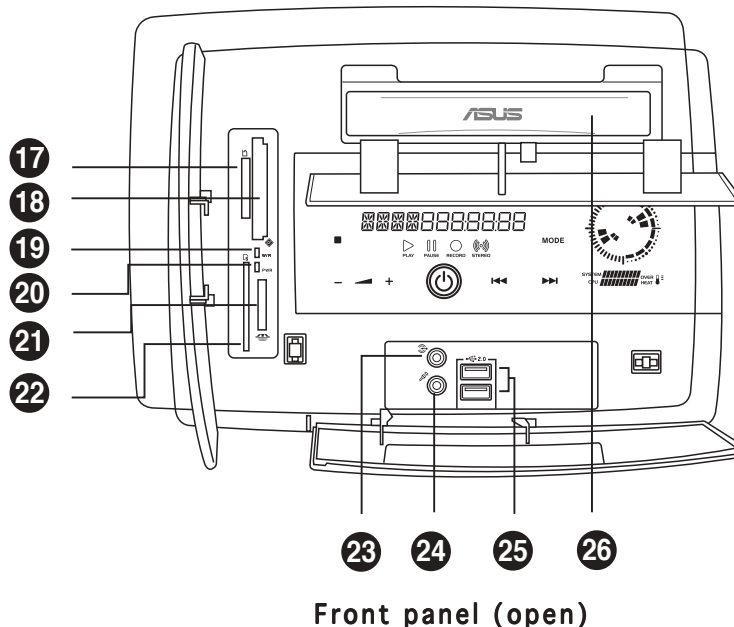

17. **Secure Digital™/MultimediaCard slot.** This slot is for a Secure Digital™/MultimediaCard storage card.
18. **CompactFlash®/Microdrive™ card slot.** This slot is for a CompactFlash®/Microdrive™ storage card.
19. **Card slot activity (W/R) LED.** This LED flashes when data is being read from or written to a storage card inserted into any of the storage card slots.
20. **Power LED.** This LED lights up when you place a storage card in any of the card slots, and turns off when you remove the card.
21. **SmartMedia® card slot.** This slot is for a SmartMedia® storage card.
22. **Memory Stick®/Memory Stick Pro™ card slot.** This slot is for a Memory Stick®/Memory Stick Pro™ storage card.
23. **Headphone port.** This port connects a headphone with a stereo mini-plug.
24. **Microphone port.** This port connects a microphone.
25. **USB 2.0 ports.** These Universal Serial Bus 2.0 (USB 2.0) ports are available for connecting USB 2.0 devices such as a mouse, printer, scanner, camera, PDA, and others.
26. **Optical drive.** This is an optional DVD-ROM/CD-RW/DVD-RW drive.

1.4 Rear panel

The S-presso rear panel includes the power socket and several I/O ports that allow convenient connection of devices.

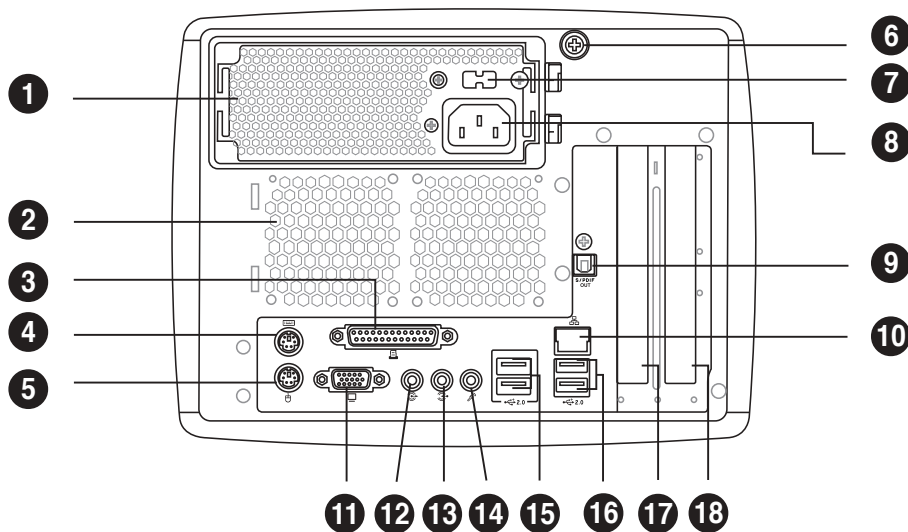

1. **Power supply unit fan.** This fan provides ventilation inside the power supply unit.
2. **Chassis fan.** This fan provides ventilation inside the system chassis.
3. **Parallel port.** This 25-pin port connects a parallel printer, a scanner, or other devices.
4. **PS/2 mouse port.** This port is for a PS/2 mouse.
5. **PS/2 keyboard port.** This port is for a PS/2 keyboard.
6. **Thumbscrew.** This thumbscrew secures the top cover to the chassis.
7. **Voltage selector.** This switch allows you to select the appropriate voltage supply in your area. See the “Voltage selector” section on page 2-18 before adjusting this switch.
8. **Power socket.** This socket connects the power cable and plug.
9. **Optical S/PDIF Out port.** This port connects an external audio output device via an optical S/PDIF cable.
10. **LAN (RJ-45) port.** This port allows connection to a Local Area Network (LAN) through a network hub.
11. **Video Graphics Adapter port.** This port connects a VGA monitor.
12. **Line Out port (lime).** This port connects a headphone or a speaker. In 4/6-channel mode, the function of this port becomes Front Speaker Out.

- 13. Line In port (light blue).** This port connects a tape, CD, DVD player, or other audio sources. In 6-channel mode, the function of this port becomes Low Frequency Enhanced Output/Center.
- 14. Microphone port (pink).** This port connects a microphone. In 4/6-channel mode, the function of this port becomes Surround Speaker.

Audio ports function variation

Port	Headphone/2-Channel	4-Channel	6-Channel
Light Blue	Line In	No function	LFE Output*/Center
Lime	Line Out	Front Speaker Out	Front Speaker Out
Pink	Mic In	Surround	Surround

- 15. USB 2.0 ports.** These two 4-pin Universal Serial Bus 2.0 (USB 2.0) ports are available for connecting USB 2.0 devices.
- 16. USB 2.0 ports.** These two 4-pin Universal Serial Bus 2.0 (USB 2.0) ports are available for connecting USB 2.0 devices.
- 17. AGP slot cover.** Remove this cover to install an AGP card.
- 18. PCI slot cover.** Remove this cover to install a PCI card.

1.5 Internal components

The illustration below is the internal view of the system when you remove the top cover. The installed components are labeled for your reference. Proceed to Chapter 2 for instructions on installing other system components.

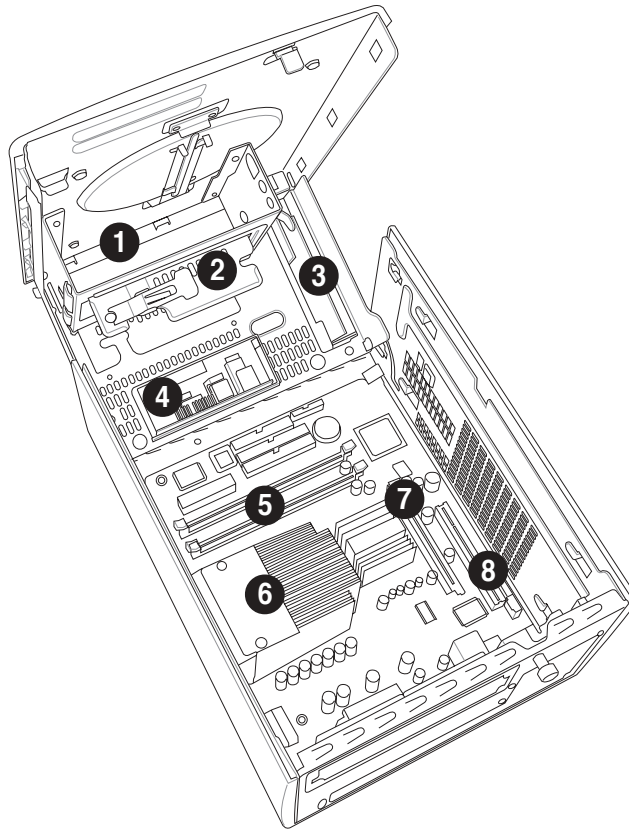

- | | |
|----------------------|------------------------------|
| 1. Optical drive bay | 5. DIMM sockets |
| 2. HDD drive bay | 6. Fan and heatsink assembly |
| 3. Storage card slot | 7. AGP card slot |
| 4. I/O slot | 8. PCI card slot |

1.6 LED panel

The S-presso LED panel on the S-presso S1-P111 model displays different system information depending on the system mode.

Below are the LED panel icons representing the different modes:



- The **Instant On** feature allows you to play DVD/VCD movies, music CD tracks, and MP3 files without entering the S-presso operating system. For details, refer to the **Software Information** user guide.
- Launch the **Home Theater** application in Windows® to play DVD/VCD movies, music CD tracks, and MP3 files, as well as watch TV, listen to FM radio, and view and print photos. For details, refer to the **Software Information** user guide.

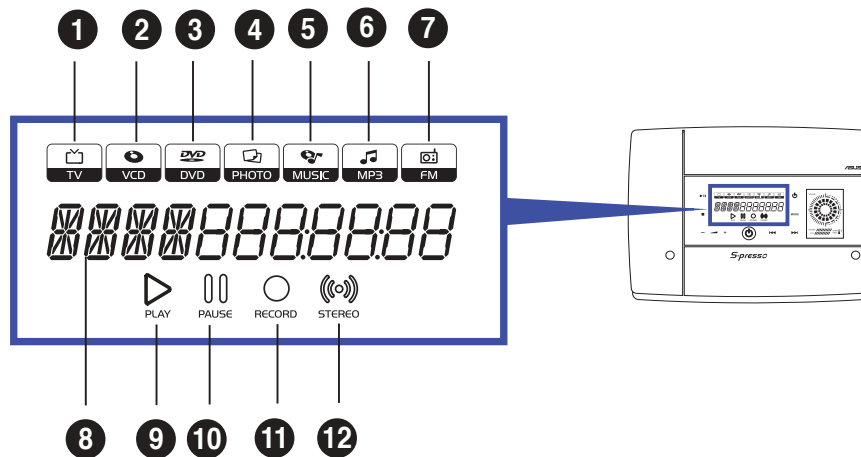

1. **TV icon** - This icon lights up when you are in TV mode, which allows you to watch TV.
2. **VCD icon** - This icon lights up when you are in VCD mode, which allows you to play video compact discs.
3. **DVD icon** - This icon lights up when you are in DVD mode. This is the default mode. When enabled, Instant On automatically goes to the DVD mode, allowing you to play digital video discs.
4. **Photo icon** - This icon lights up when you are in Photo mode, which allows you to view and print photos.
5. **Music icon** - This icon lights up when you are in Music mode, which allows you to play audio compact discs (CDs).
6. **MP3 icon** - This icon lights up when you are in MP3 mode, which allows you to play music in MP3 format, whether in discs or as files saved in your computer.
7. **FM icon** - This icon lights up when you are in FM mode, which allows you to listen to FM radio.

8. **Status display.** When the system is powered off, in soft-off or stand-by mode, S3 (Suspend-to-RAM), or S4 (Suspend-to-Disk) state, this displays the system time. The panel displays the system time in 24-hour format. Enter the BIOS setup or the S-presso operating system to adjust the time.

In Instant On, this displays the current mode.

When playing a video or music disc, this display shows the chapter number of the movie, or the track number of the music disc, as well as the track duration and time elapsed .

9. **Play.** This LED lights up to indicate that a movie or audio track is playing.
10. **Pause.** This LED lights up to indicate that a movie or audio track has been paused.
11. **Record.** This LED lights up to indicate that you are recording a movie or audio track.
12. **Stereo.** This LED lights up to indicate that your TV audio setting is Stereo.

Chapter 2

This chapter provides step-by-step instructions on how to install components in the system.

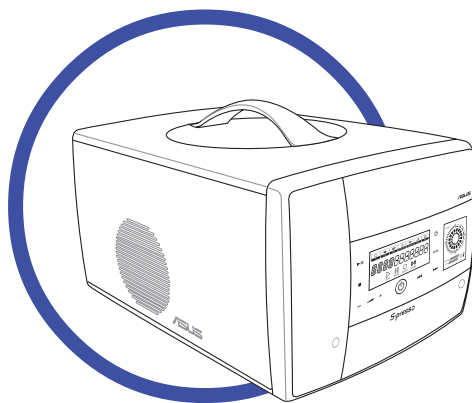

ASUS S-presso barebone system

2.1 Preparation

Before you proceed, make sure that you have all the components that you plan to install in the system.

Basic components to install

1. Central processing unit (CPU)
2. DDR Dual Inline Memory Module (DIMM)
3. Expansion card(s)
4. Hard disk drive
5. Optical drive

Tool

Phillips (cross) screw driver

2.2 Before you proceed

Take note of the following precautions before you install components into the system.



- Use a grounded wrist strap or touch a safely grounded object or a metal object, such as the power supply case, before handling components to avoid damaging them due to static electricity.
- Hold components by the edges to avoid touching the ICs on them.
- Whenever you uninstall any component, place it on a grounded antistatic pad or in the bag that came with the component.

The motherboard comes with an onboard standby power LED. This LED lights up to indicate that the system is ON, in sleep mode or in soft-off mode, and not powered OFF. Unplug the power cable from the power outlet and make sure that the standby power LED is OFF before installing any system component.

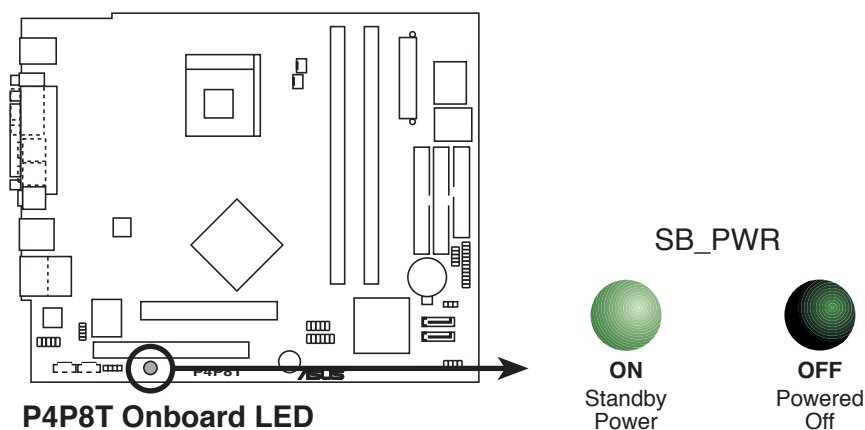

2.3 Removing the front panel

To remove the front panel:

1. Locate the groove under the front panel.
2. Position your four fingers under the groove, with your thumb supporting the lower portion of the front panel.
3. Slightly pull towards you until the lower portion disengages from the chassis.



Do not use excessive force to avoid breaking the front panel.

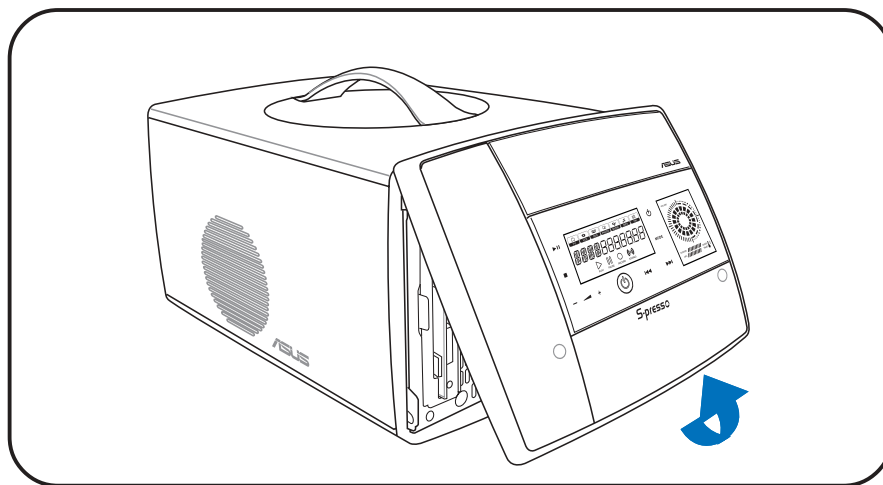

4. Slightly pull the side and top portions to completely release the front panel from the chassis.
5. Set the front panel aside.

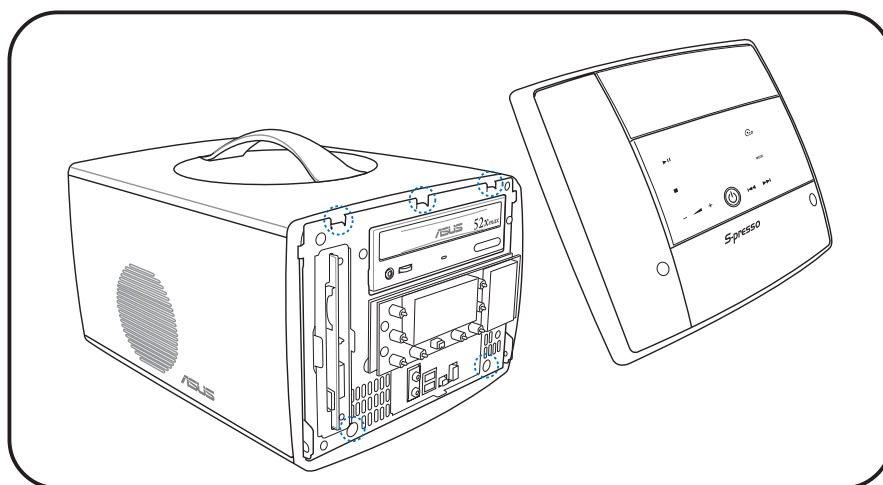

2.4 Removing the cover

To remove the cover:

1. On the rear panel, locate the thumbscrew that secures the cover to the chassis.
2. Turn the thumbscrew counterclockwise until it gets loose.



The thumbscrew cannot be removed from the chassis.

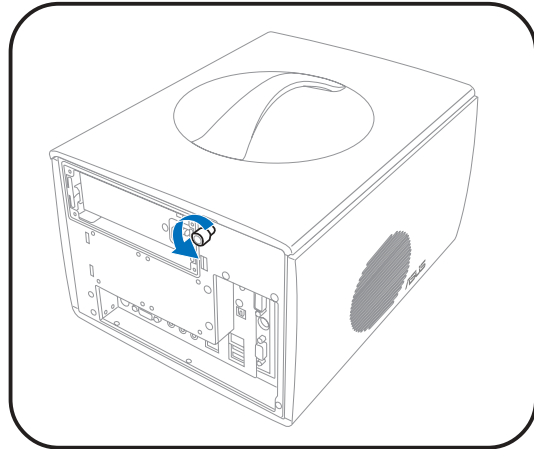

3. Firmly grip the top handle and push the cover about 1 cm forward.

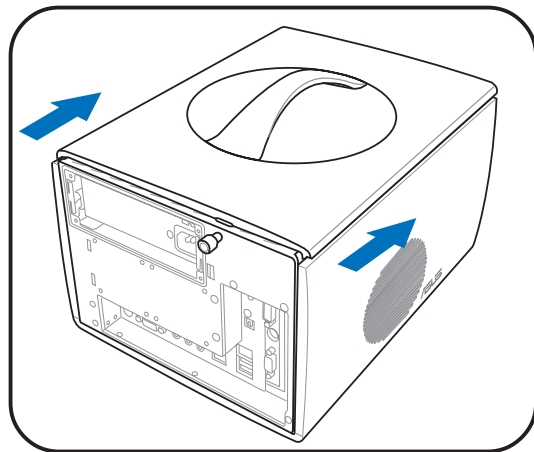

4. Lift the cover to expose the internal components of your system.



The cover does not completely disengage from the chassis.



When fully open, the cover remains tilted at an angle of about 35°. Do not push down further to prevent damage to the system.

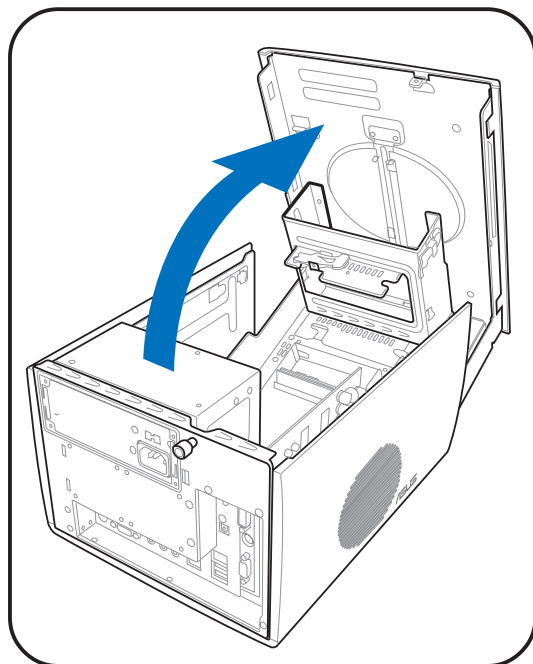

2.5 Removing the power supply unit

You must remove the power supply unit (PSU) before you can install a central processing unit (CPU) and other system components.

To remove the PSU:

1. Disconnect the power plugs on the motherboard.
2. Locate the lever that secures the PSU.
3. Push down the lever to release the PSU.

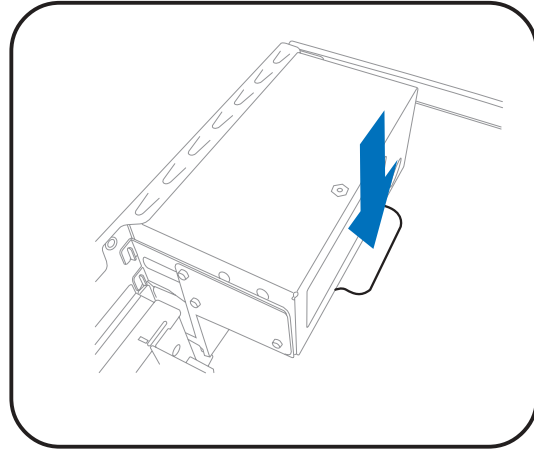

4. Slide the PSU out of the metal tray.



When removing the PSU, make sure to hold or support it firmly. The unit might accidentally drop and damage the other system components.

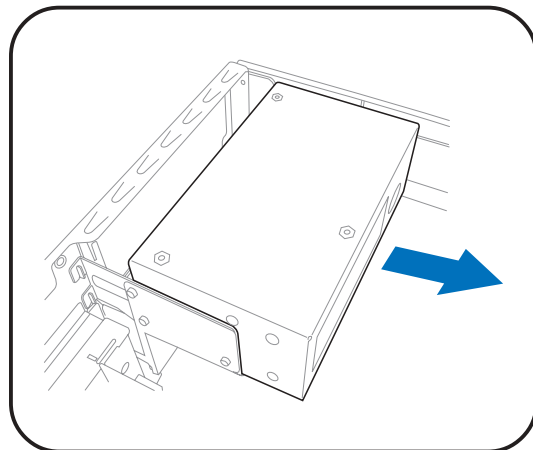

5. Set the PSU aside.
6. Lift up the metal tray and set it aside.

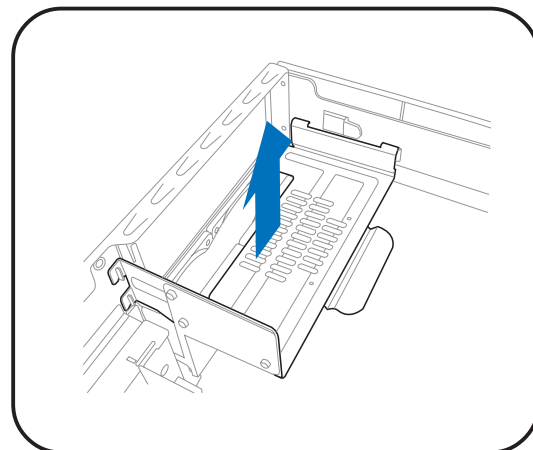

2.6 Installing a CPU

The motherboard comes with a surface mount 478-pin Zero Insertion Force (ZIF) socket. This socket is designed for an Intel® Pentium® 4 processor with up to 3.4 GHz core frequency and 800 MHz FSB.

2.6.1 Removing the CPU fan and heatsink assembly

The system package includes a pre-installed proprietary CPU fan and heatsink assembly to ensure optimum thermal condition and performance.



DO NOT replace the proprietary CPU fan and heatsink with other models.

You must remove the CPU fan and heatsink assembly before you can install a CPU.

To remove the CPU fan and heatsink assembly:

1. Unplug the fan cable from the motherboard.
2. Using a Phillips screw driver, remove the four screws that secure the CPU fan and heatsink assembly to the motherboard.
3. Lift the CPU fan and heatsink assembly, then set it aside.

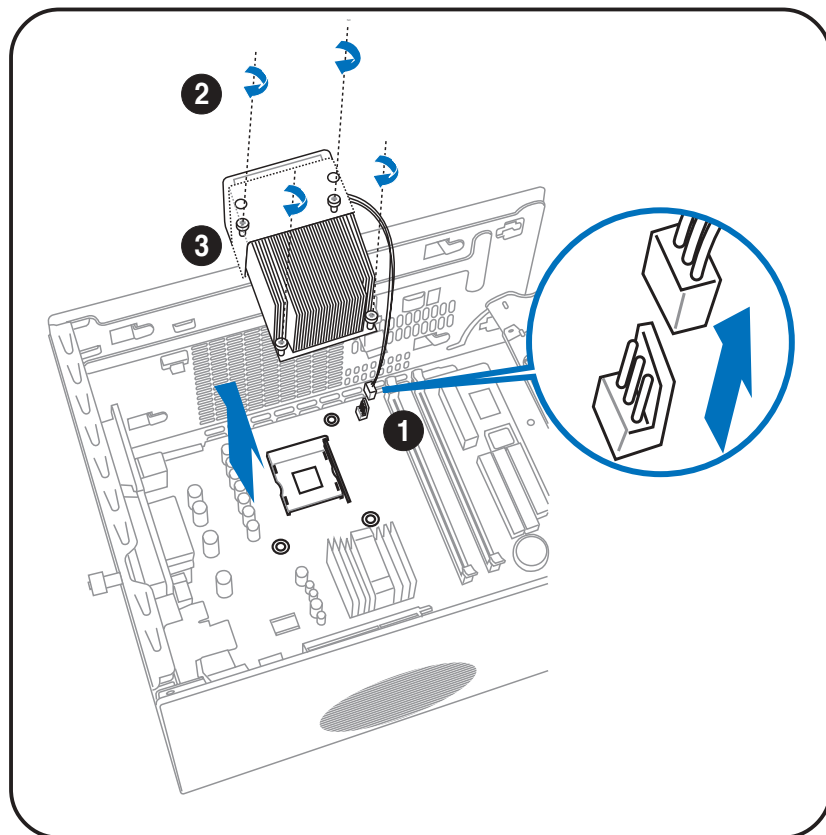

2.6.2 CPU installation

To install the CPU:

1. Locate the 478-pin CPU socket on the motherboard.
2. Unlock the socket by pressing the lever sideways.
3. Lift the lever up to a 90° angle.
4. Position the CPU above the socket such that its marked corner (gold mark) matches the base of the socket lever.
5. Carefully insert the CPU into the socket until it fits in place.
6. Push down the socket lever to secure the CPU. The lever clicks on the side tab to indicate that it is locked.

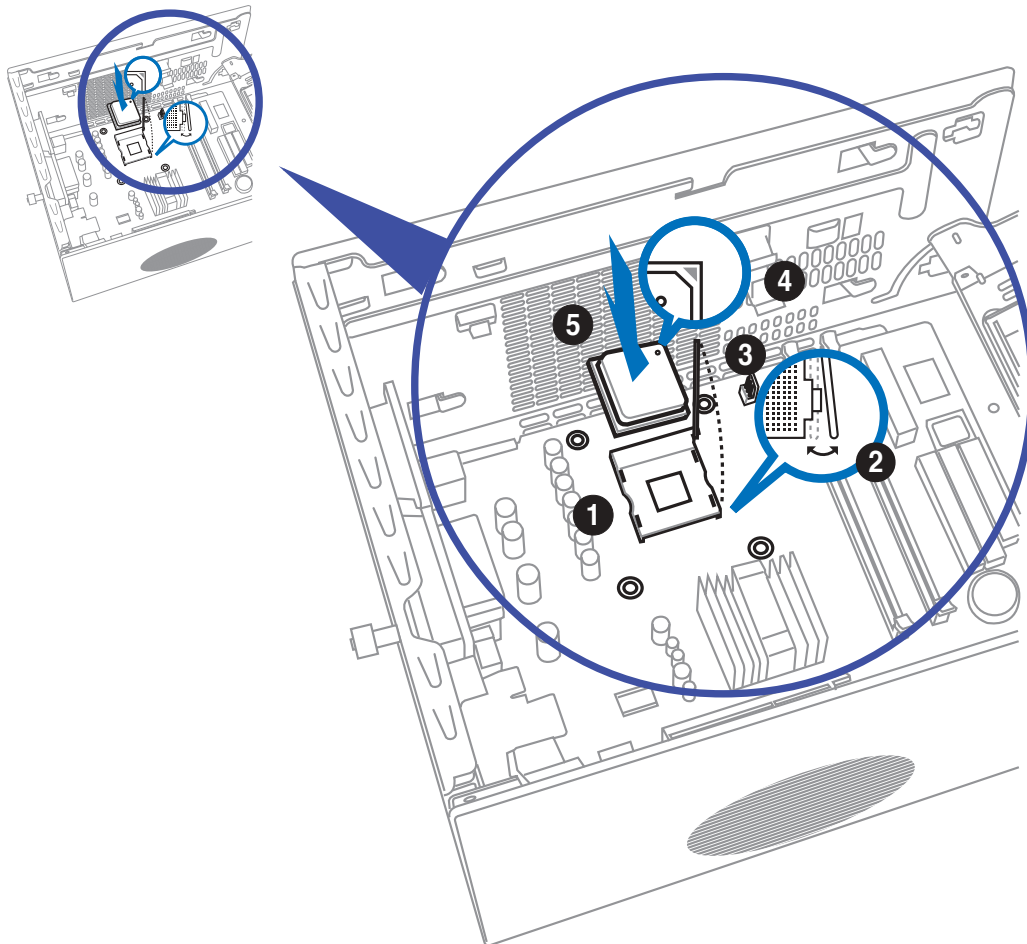

2.6.3 Re-installing the CPU fan and heatsink assembly

To re-install the CPU fan and heatsink assembly:

1. Position the CPU fan and heatsink assembly on top of the installed CPU.
2. Using a Phillips screw driver, secure the CPU fan and heatsink assembly to the motherboard with the four screws your removed earlier.
3. Connect the fan cable to the fan connector on the motherboard.

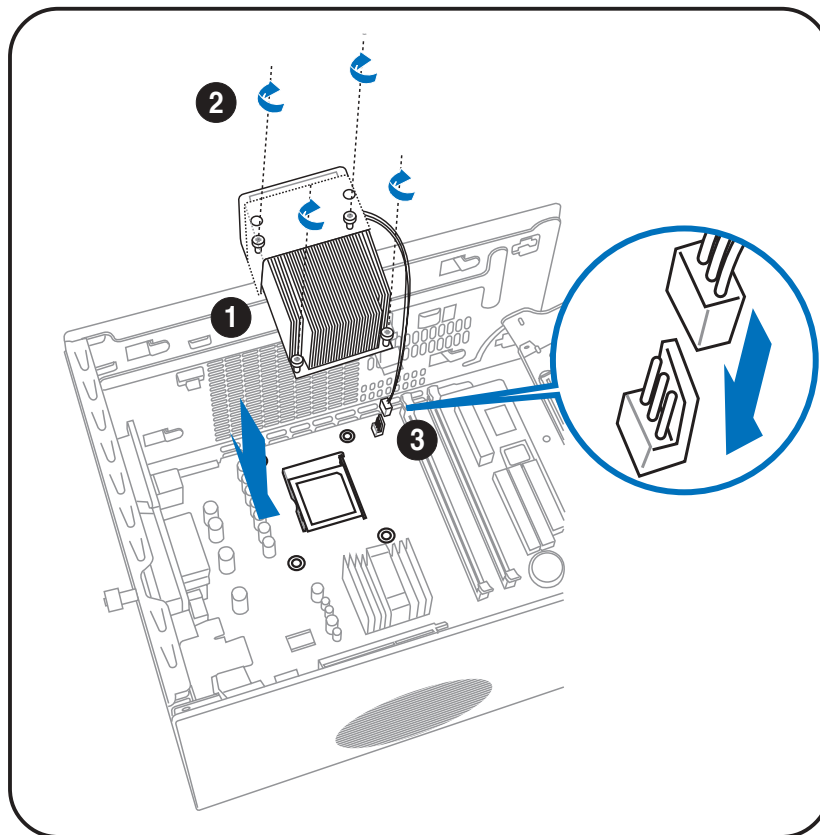

Do not forget to connect the CPU fan connector! Hardware monitoring errors may occur if you fail to plug this connector.

2.7 Installing a DIMM

The system motherboard comes with two Double Data Rate (DDR) Dual Inline Memory Module (DIMM) sockets that support dual-channel memory configuration using unbuffered non-ECC PC3200/2700/2100 DIMMs.

2.7.1 Memory configurations

You may install up to 2 GB system memory using 64 MB, 128 MB, 256 MB, 512 MB, and 1 GB DDR DIMMs.



Obtain DDR DIMMs only from ASUS qualified vendors. Refer to the Qualified DDR400 vendors list below. Visit the ASUS website (www.asus.com) for the latest DDR Qualified Vendors List.

Qualified DDR400 vendors list

This table lists the memory modules that have been tested and qualified for use with this motherboard.

Size	Vendor	Part Number	Chip Brand	Chip Number
256MB	Samsung	M368L3223DTM-CC4	Samsung	K4H560838D-TCC4
256MB	Samsung	M368L3223ETM-CCC	Samsung	K4H560838E-TCCC
512MB	Samsung	M368L6432ETM-CCC	Samsung	K4H560838E-TCCC
256MB	Infineon	HYS64D32300GU-5-B	Infineon	HYB25D256800BT-5B
512MB	Infineon	HYS64D64320GU-5-B	Infineon	HYB25D256800BT-5B
256MB	Transcend	TS32MLD64V4F3	Samsung	K4H560838D-TCC4
512MB	Transcend	TS64MLD64V4F3	Samsung	K4H560838D-TCC4
256MB	Winbond	W9425GCDB-5	Winbond	W942508CH-5
512MB	Winbond	W9451GCDB-5	Winbond	W942508CH-5
256MB	A DATA	MDOAD5F3G315B1ECZ	Samsung	K4H560838D-TCC4
256MB	TwinMOS	MDSTTUF08108L294K4FW0/T	TwinMOS	TMD7608F8E50B
512MB	Hynix	HYMD264646B8J-D43 AA	Hynix	HY5DU56822BT-D43
512MB	Apacer	77.10636.465	Samsung	K4H560838D-TCC4



- Install only **identical** (the same type and size) DDR DIMM in DIMM_A and DIMM_B.
- Always install DIMMs with the same CAS latency. For optimum compatibility, we recommend that you obtain memory modules from the same vendor.
- This motherboard only supports x4, x8, x16 chips per module DDR DIMMs.
- Make sure that the memory frequency matches the CPU FSB (Front Side Bus). Refer to the Memory frequency/CPU FSB synchronization table on the next page.

Memory frequency/CPU FSB synchronization

The system motherboard supports different memory frequencies depending on the CPU FSB (Front Side Bus) and the type of DDR DIMM.

CPU FSB	DDR DIMM Type	Memory Frequency
800 MHz	PC3200/PC2700*/PC2100	400/333*/266 MHz
533 MHz	PC2700/PC2100	333/266 MHz
400 MHz	PC2100	266 MHz



*When using 800 MHz CPU FSB, PC2700 DDR DIMMs may run only at 320 MHz (not 333 MHz) due to chipset limitation.

2.7.2 DIMM installation

To install a DDR DIMM:

1. Locate the two DIMM sockets on the motherboard.
2. Unlock a socket by pressing the retaining clips outward.
3. Align a DIMM on the socket such that the notch on the DIMM matches the break on the socket.
4. Firmly insert the DIMM into the socket until the retaining clips snap back in place and the DIMM is properly seated.

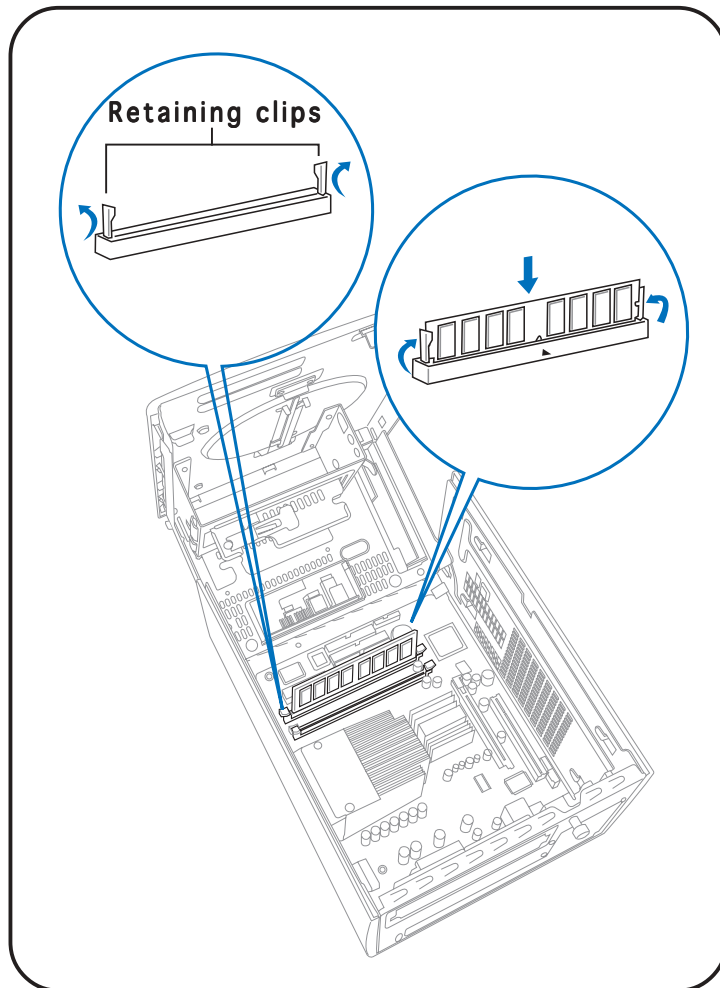

A DDR DIMM is keyed with a notch so that it fits in only one direction. DO NOT force a DIMM into a socket to avoid damaging the DIMM!

2.8 Installing an expansion card

In the future, you might need to install expansion cards. The motherboard has one PCI and one Accelerated Graphics Port (AGP) slot. The following sub-sections describe the slots and the expansion cards that they support.

2.8.1 Expansion slots

PCI slot

The PCI slot supports PCI cards such as a LAN card, SCSI card, USB card, and other cards that comply with PCI specifications.

AGP slot

The AGP slot supports AGP 8X (+0.8V) cards and AGP 4X (+1.5V) cards. When you buy an AGP card, make sure that you ask for one with +0.8V or +1.5V specification.



Install only +0.8V or +1.5V AGP cards. The P4P8T motherboard does not support 3.3V AGP cards.



Unplug the power cord before adding or removing expansion cards. Failure to do so can cause you physical injury and damage the motherboard.

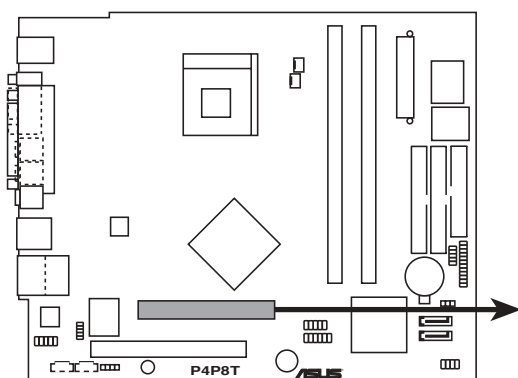

P4P8T Accelerated Graphics Port (AGP)

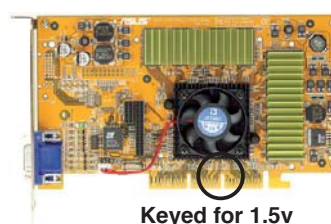

2.8.2 Expansion card installation

To install an expansion card:

1. Before installing the expansion card, read the documentation that came with it and make the necessary hardware settings for the card.
2. Locate the hinge lock that secures the expansion card slot.
3. Push down the hinge lock handle and lift towards the direction of the arrow.

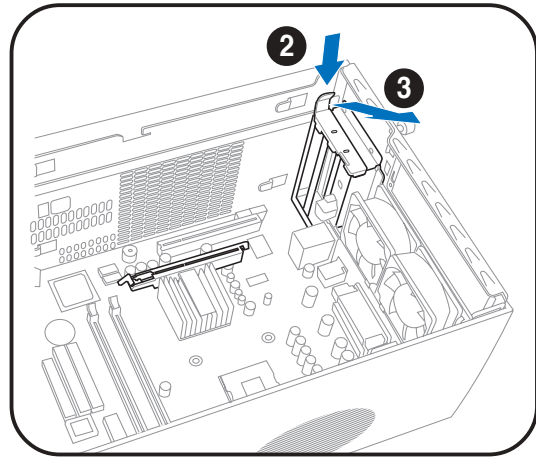

4. Align the card connector with the slot and press firmly until the card is completely seated in the slot.

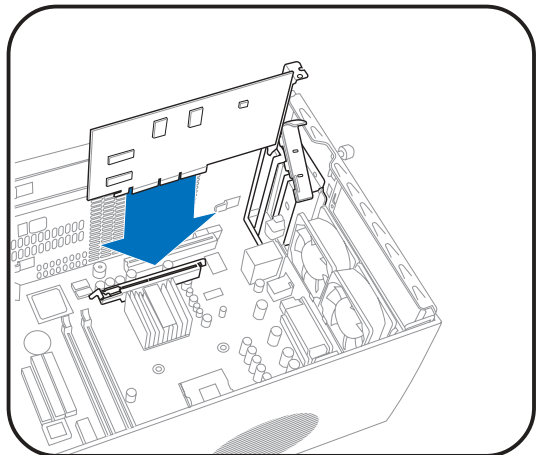

5. Replace the hinge lock to secure the card to the chassis.
6. Press down firmly until the hinge lock snaps in place.

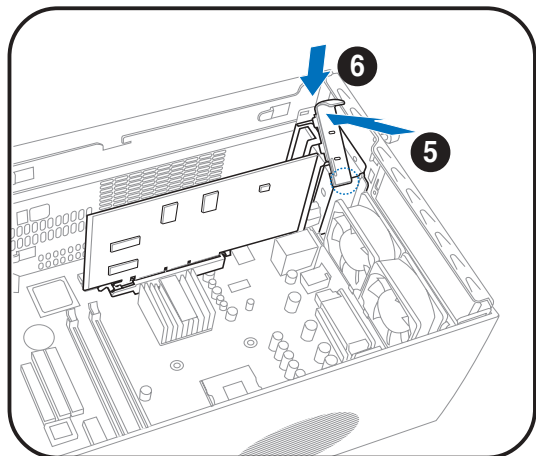

2.8.3 Configuring an expansion card

After installing the expansion card, configure it by adjusting the software settings.

1. Turn on the system and change the necessary BIOS settings, if any. See Chapter 3 for information on the BIOS setup.
2. Assign an IRQ to the card. Refer to the tables on the next page.
3. Install the software drivers for the expansion card.

Standard interrupt assignments

IRQ	Standard Function
0	System Timer
1	Keyboard Controller
7*	Printer Port (LPT1)
8	System CMOS/Real Time Clock
9*	ACPI Mode when used
10*	IRQ Holder for PCI Steering
11*	IRQ Holder for PCI Steering
12*	PS/2 Compatible Mouse Port
13	Numeric Data Processor
14*	Primary IDE Channel
15*	Secondary IDE Channel

* These IRQs are usually available for ISA or PCI devices.

IRQ assignments for this motherboard

	A	B	C	D	E	F	G	H
PCI slot 1	--	shared	--	--	--	--	--	--
AGP slot	shared	shared	--	--	--	--	--	--
Onboard USB controller HC0	shared	--	--	--	--	--	--	--
Onboard USB controller HC1	--	--	--	shared	--	--	--	--
Onboard USB controller HC2	--	--	shared	--	--	--	--	--
Onboard USB controller HC3	shared	--	--	--	--	--	--	--
Onboard USB 2.0 controller	--	--	--	--	--	--	--	used
Onboard LAN	--	--	--	--	--	--	used	--
Onboard Audio	--	shared	--	--	--	--	--	--



When using a PCI card on shared slots, ensure that the drivers support “Share IRQ” or that the cards do not need IRQ assignments; otherwise, conflicts will arise between the two PCI groups, making the system unstable and the card inoperable.

2.9 Installing an optical drive

The S-presso system comes with one optical drive bay. Refer to this section to install an optical drive.



Set your optical drive as Slave device before connecting the IDE cable and power plug. Refer to the optical drive documentation on how to set the drive as a Slave device.

To install an optical drive:

1. Drive a screw on each side of the optical drive as shown.

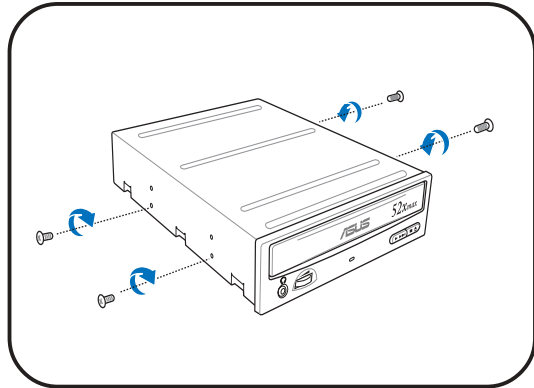

2. Remove the front panel. Refer to section “2.3 Removing the front panel” for instructions.
3. Slide the optical drive into the optical drive bay.

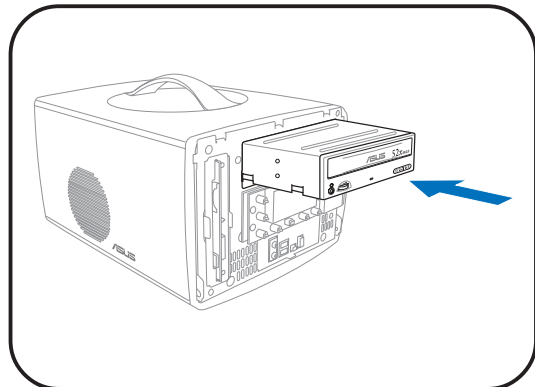

4. Push the optical drive until the hinge lock snaps the screws into place.

5. Connect a power cable from the power supply unit to the power connector at the back of the optical drive.
6. Connect one end of the IDE ribbon cable to the IDE interface at the back of the optical drive, matching the red stripe on the cable with Pin 1 on the IDE interface.
7. Connect one end of the optical drive audio cable to the 4-pin connector at the back of the optical drive.
8. Connect the other end of the IDE ribbon cable to the secondary IDE connector (black connector labeled SEC_IDE) on the motherboard. See page 3-8 for the location of the secondary IDE connector.
9. Connect the other end of the audio cable to the 4-pin CD1 connector on the motherboard. See page 3-8 for the location of the CD audio connector.

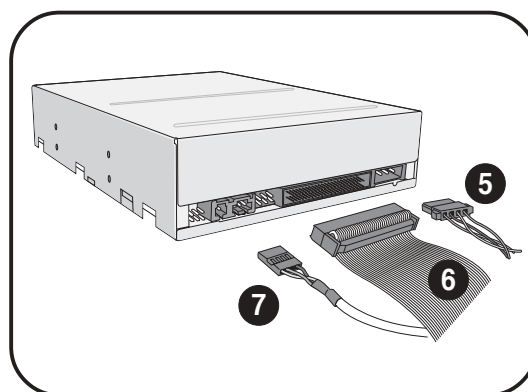

2.10 Installing a hard disk drive

The system supports one Ultra ATA/133 IDE hard disk drive (HDD).

To install a hard disk drive:

1. Drive two screws in each side of the hard disk drive as shown.

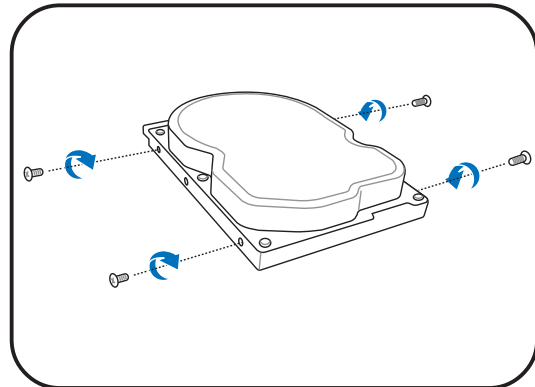

2. Remove the cover. Refer to section “2.4 Removing the cover” for instructions.
3. Position the hard disk drive at the bottom of the drive bay, then slide it inside.
4. Push in the direction of the arrow until the clamp snaps to secure the four screws you put in earlier.

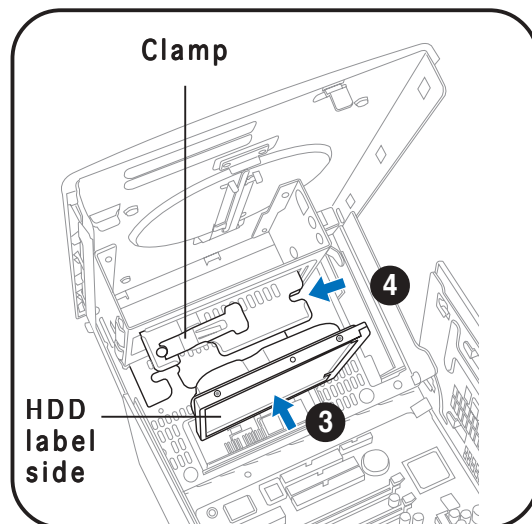

5. Connect one end of the 40-pin IDE cable to the IDE connector on the drive.
6. Connect a 4-pin power plug from the power supply unit to the HDD power connector.
7. Connect the other end of the IDE ribbon cable to the primary IDE connector (blue connector labeled PRI_IDE) on the motherboard. See page 3-8 for the location of the primary IDE connector.

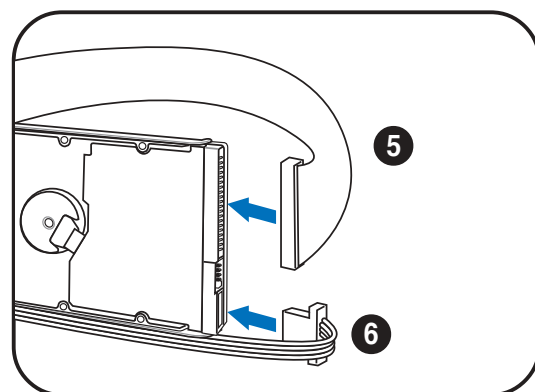

Configure your hard disk drive as Master device before connecting the IDE cable and power plug. Refer to the HDD documentation on how to set the drive as a Master device.

2.11 Re-installing the power supply unit

Re-install the power supply unit (PSU) after installing the system components and reconnecting the cables.

To reinstall the PSU:

1. Replace the metal tray. Make sure that the hooks align to their respective grooves.

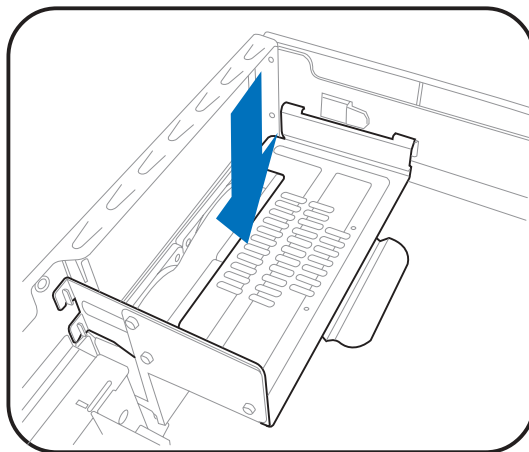

2. Slide the PSU toward the direction of the rear panel until it fits in place.

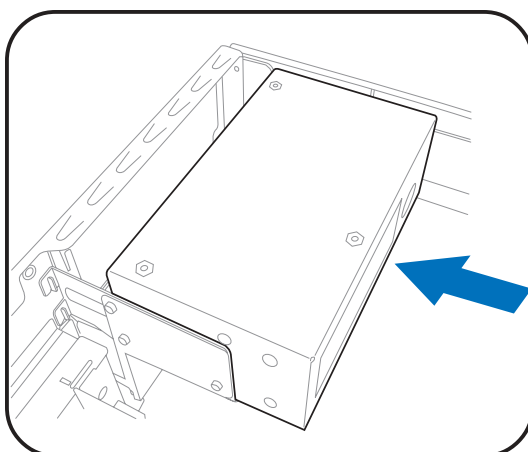

3. Connect the power plugs to the connectors on the motherboard. See next page for details.



Make sure that the PSU cables do not interfere with the CPU and/or chassis fans.

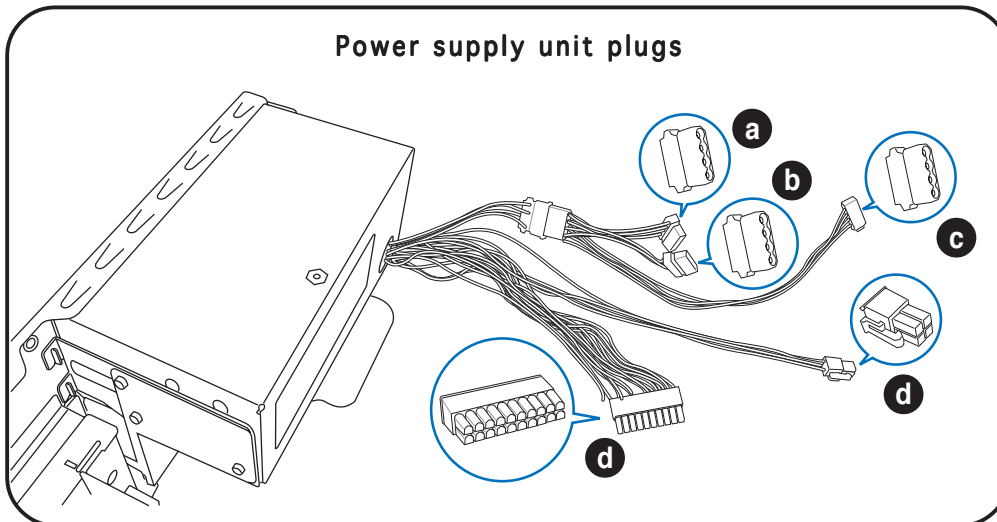

- a. Connect the 4-pin power plug to the power connector of the optical disk drive.
- b. Connect the 4-pin power plug to the power connector of the VGA card.
- c. Connect the 4-pin power plug to the power connector of the hard disk drive.
- d. Connect the 4-pin 12 V and the 20-pin ATX power plugs to the ATX12V and ATXPWR connectors, respectively. See page 3-7 for the location of these connectors.

2.11.1 Voltage selector

The PSU has a 115 V/230 V voltage selector switch located beside the power connector. Use this switch to select the appropriate voltage according to the voltage supply in your area.

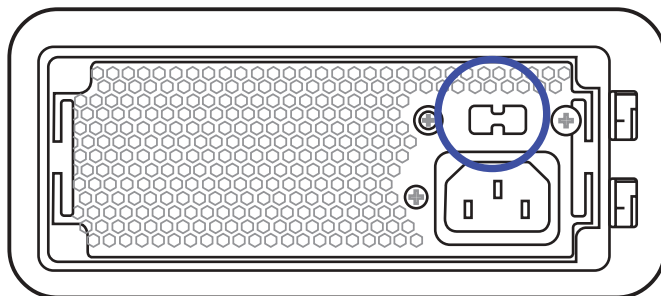

If the voltage supply in your area is 100-127 V, set the switch to 115 V.



The voltage selector is set to 115 V by default.

If the voltage supply in your area is 200-240 V, set the switch to 230 V.



Setting the switch to 115 V in a 230 V environment will seriously damage the system!

2.11.2 Power supply specifications

Input characteristics

Input Voltage Range	Min	Nom	Max
Range 1	90 V	115 V	132 V
Range 2	180 V	230 V	264 V
Input Frequency Range	47 Hz ~ 63 Hz		
Maximum Input AC Current	5 A maximum at 115 Vac 3 A maximum at 230 Vac, full load		
Inrush Current	45 A at 115 Vrms 90 A at 230 Vrms (at 25°C ambient cold start)		

Output voltage requirements

Parameter	Range	Min	Nom	Max	Unit
+3.3 V	+/-5%	+3.14	+3.3	+3.47	Volts
+5 V	+/-5%	+4.75	+5	+5.25	Volts
+12 V	+/-5%	+11.4	+12.0	+12.6	Volts
-12 V	+/-10%	-10.8	-12.0	-13.2	Volts
+5 VSB	+/-5%	+4.75	+5	+5.25	Volts



- At no load, +3.3 V output +/-5% regulation limits do not apply.
- At +12 V surge, regulation can go up to +/-10%.

DC output current load ranges

Parameter	Min	Nom	Max	Peak	Unit
+3.3 V	0.5	-	17.0	-	Amps
+5 V	0.3	-	13.0	-	Amps
+12 V	1.0	-	16.0	17.0	Amps
-12 V	0.0	-	0.3	-	Amps
+5 VSB	0.0	-	2.0	2.5	Amps



- +5 VSB is an SELV standby voltage that is always present when AC main voltage is present.
- The maximum continuous average DC output power should not exceed 220 W.
- The maximum combined load on +5 V and +3.3 V outputs should not exceed 80 W.
- The maximum peak total DC output power should not exceed 225 W.
- Peak +12 VDC output power should not exceed a duration of 12 seconds.

Output ripple

Parameter	Ripple & Noise Max	Unit
+3.3 V	100	mVp-p
+5 V	100	mVp-p
+12 V	150	mVp-p
-12 V	150	mVp-p
+5 VSB	100	mVp-p

2.11 Replacing the cover

To replace the cover:

1. Push down the top cover.

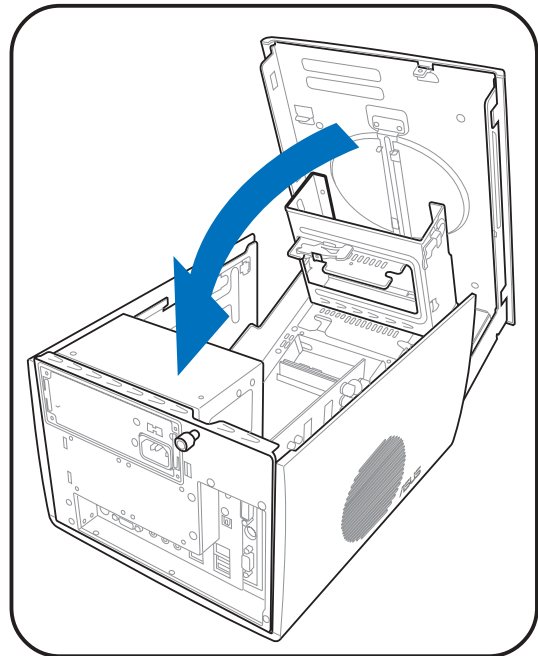

- 2.. Push to the direction of the arrow until the rear portion of the cover aligns with the metal railing on the rear panel.

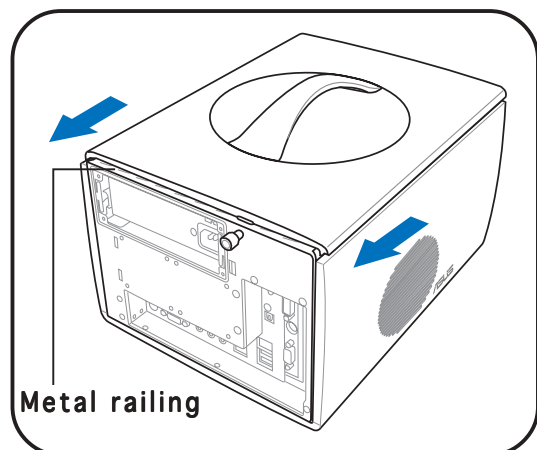

3. Tighten the screw by turning it clockwise to secure the cover to the rear panel.

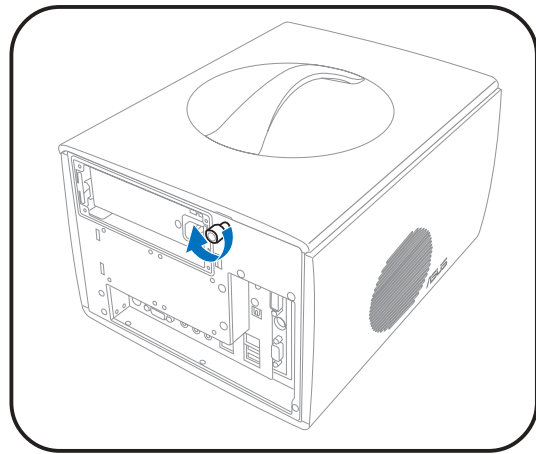

2.12 Connecting external devices

To the front panel

S1-P111

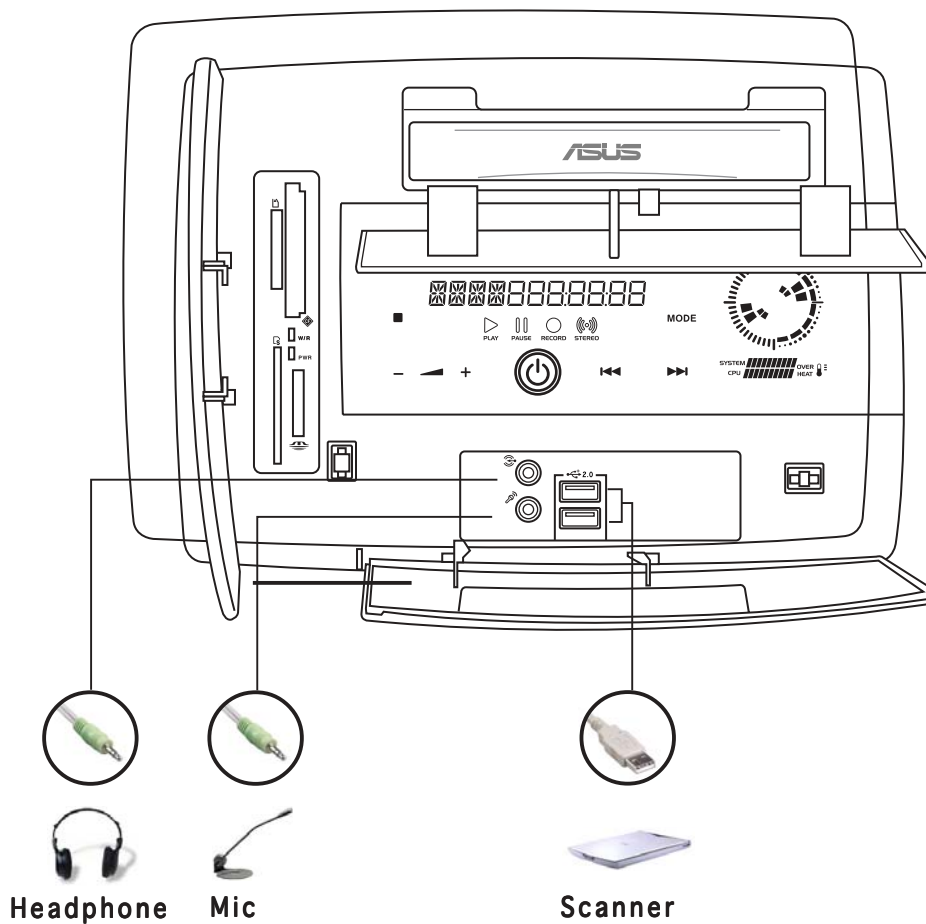

To the rear panel

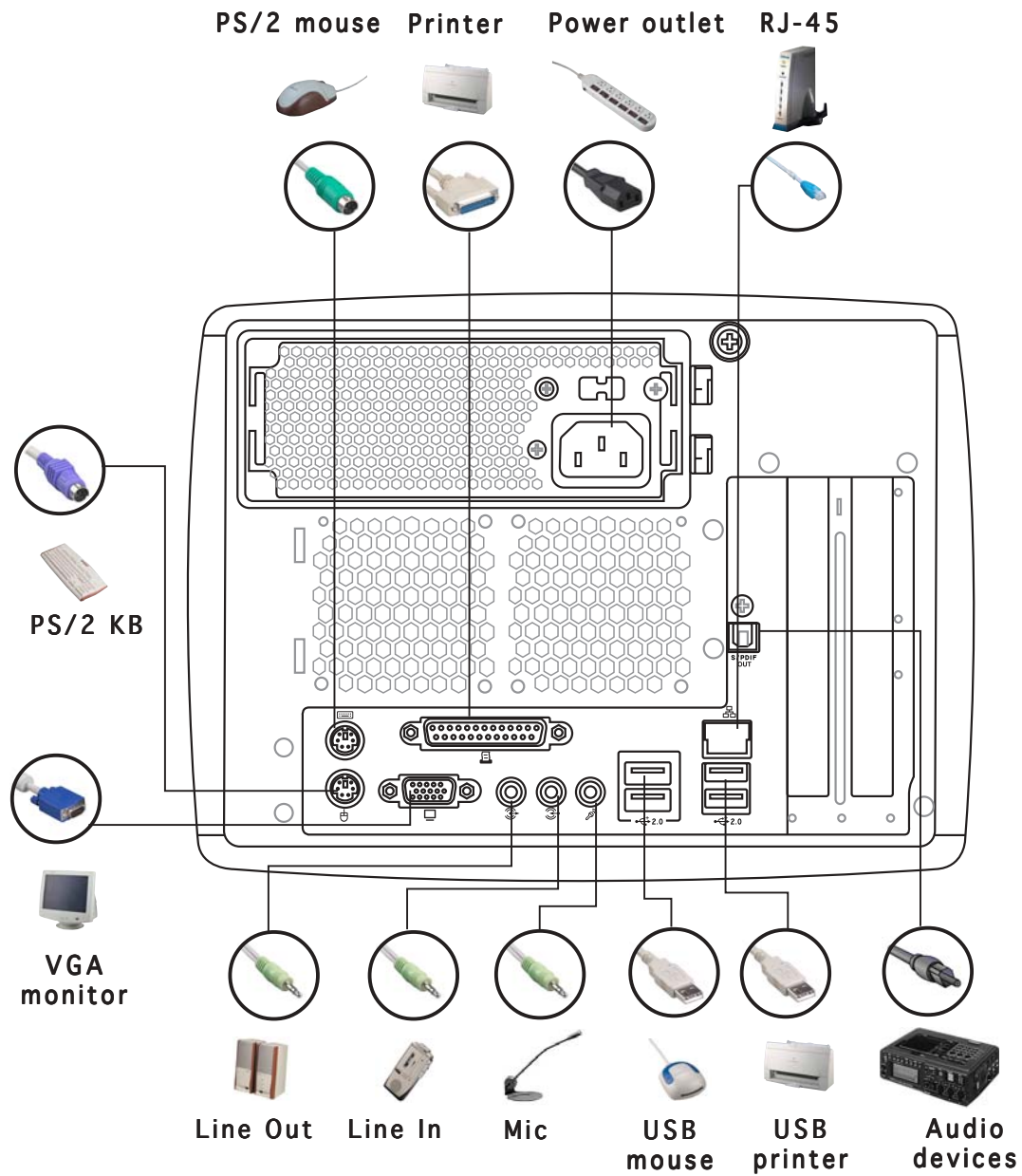

Chapter 3

This chapter gives information about the motherboard that comes with the system. This chapter includes the motherboard layout, jumper settings, and connector locations.

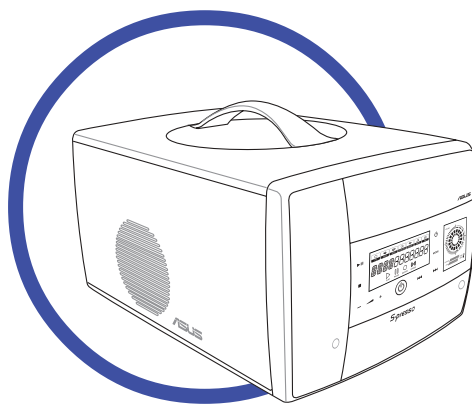

ASUS S-presso barebone system

3.1 Introduction

The ASUS P4P8T motherboard comes already installed in the ASUS S-presso barebone system. This chapter provides technical information about the motherboard for future upgrades or system reconfiguration.

3.2 Motherboard layout

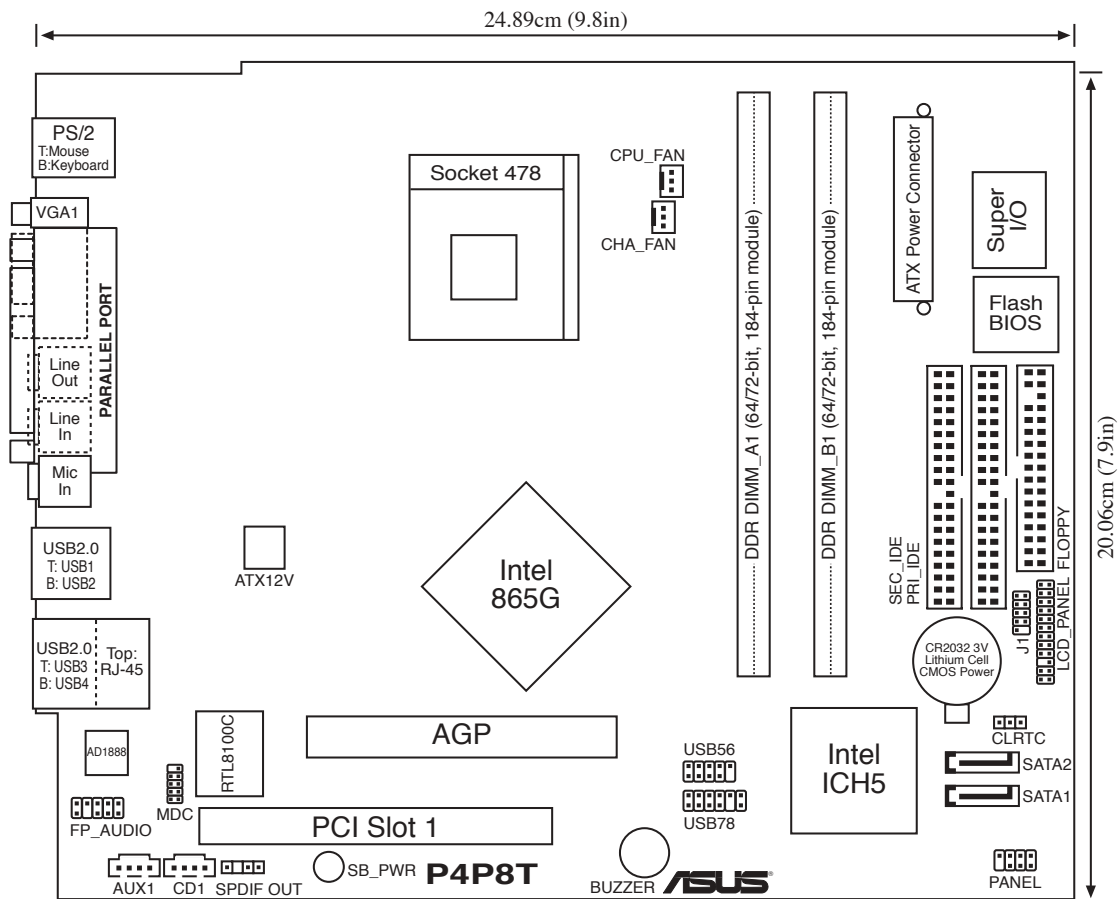

3.3 Jumper

Clear RTC RAM (CLRRTC)

This jumper allows you to clear the Real Time Clock (RTC) RAM in CMOS. You can clear the CMOS memory of date, time, and system setup parameters by erasing the CMOS RTC RAM data. The onboard button cell battery powers the RAM data in CMOS, which include system setup information such as system passwords.

To erase the RTC RAM:

1. Turn OFF the computer and unplug the power cord.
2. Remove the battery.
3. Move the jumper cap from pins 1-2 (default) to pins 2-3. Keep the cap on pins 2-3 for about 5-10 seconds, then move the cap back to pins 1-2.
4. Re-install the battery.
5. Plug the power cord and turn ON the computer.
6. Hold down the key during the boot process and enter BIOS setup to re-enter data.



Except when clearing the RTC RAM, never remove the cap on CLRRTC jumper default position. Removing the cap will cause system boot failure!

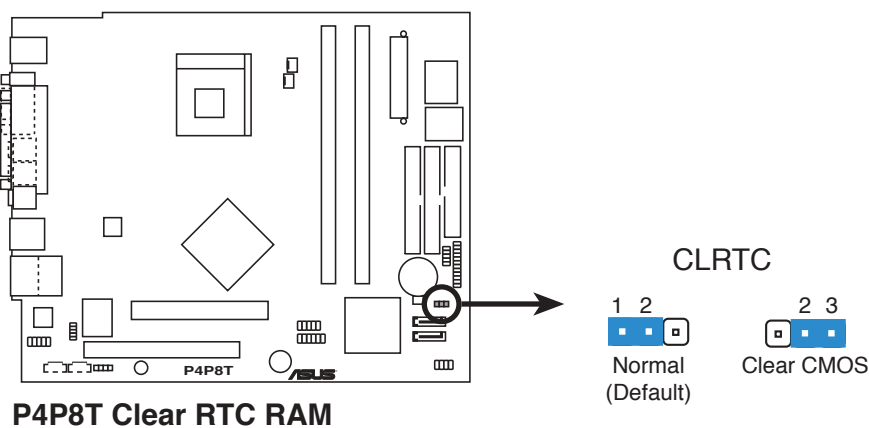

The system automatically turns on when you clear the CMOS after first reboot.

3.4 Connectors

This section describes and illustrates the connectors on the motherboard. See page 1-6 for the description of rear panel connectors.

1. USB connectors (10-1 pin USB56, 10-1 pin USB78)

These connectors are for USB 2.0 ports. Connect the USB/GAME module cable to any of these connectors, then install the module to a slot opening at the back of the system chassis. These USB connectors comply with USB 2.0 specification that supports up to 480 Mbps connection speed.

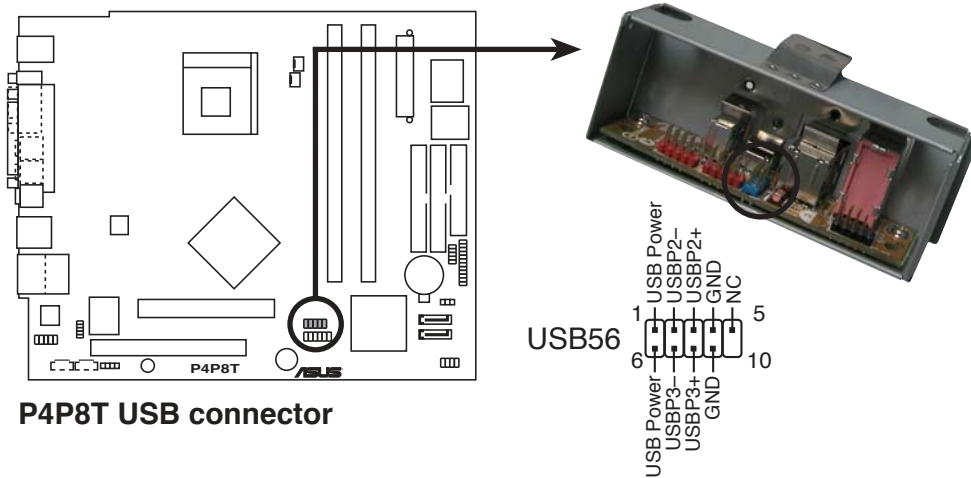

P4P8T USB connector

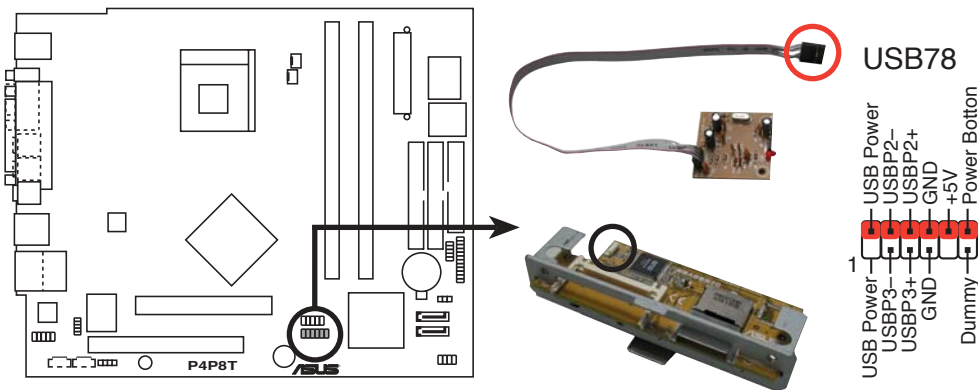

P4P8T USB connector

2. Digital audio connector (4-1 pin SPDIF OUT)

This connector is for a Sony/Philips Digital Interface (S/PDIF) port. Connect the S/PDIF module cable to this connector, then install the module to a slot opening at the back of the system chassis.



The S/PDIF module is purchased separately.

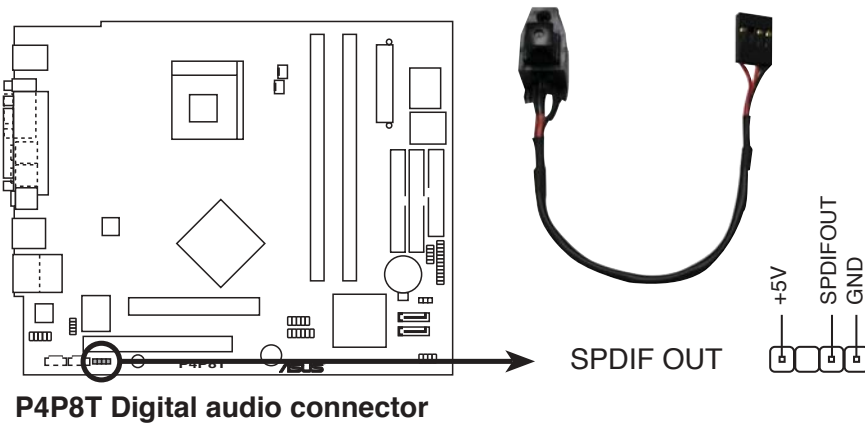

3. Front panel audio connector (10-1 pin FP_AUDIO)

This connector is for a chassis-mounted front panel audio I/O module that supports AC`97 audio standard. Connect one end of the front panel audio I/O module cable to this connector.

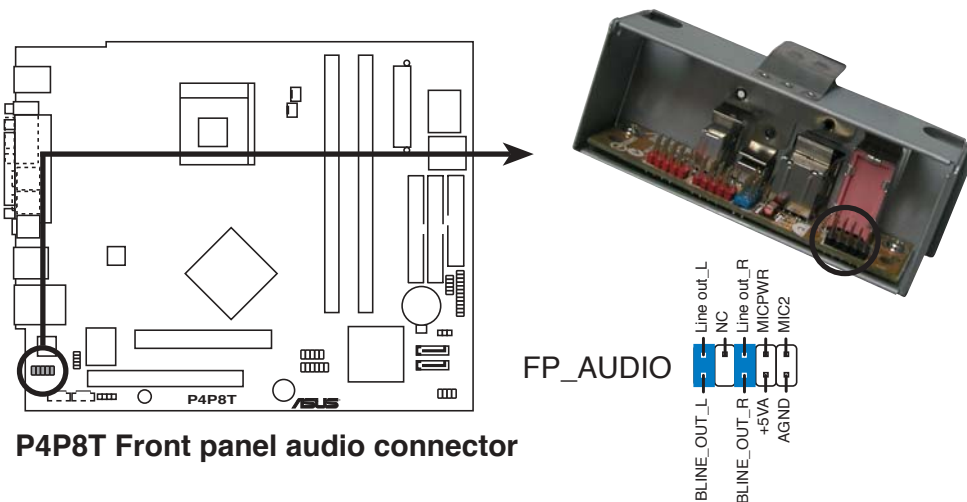

4. CPU and chassis fan connectors (3-pin CPU_FAN, CHA_FAN)

The fan connectors support cooling fans of 350 mA ~ 2000 mA (24 W max.) or a total of 1 A ~ 3.48 A (41.76 W max) at +12 V. Connect the fan cables to the fan connectors on the motherboard, making sure that the black wire of each cable matches the ground pin of the connector.

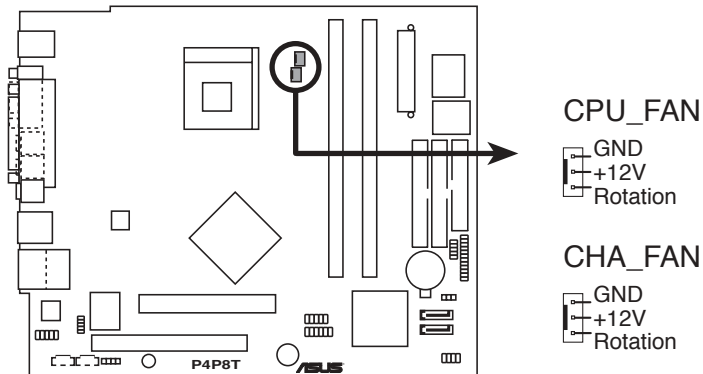

P4P8T Fan connectors



Do not forget to connect the fan cables to the fan connectors. Insufficient air flow within the system may damage the motherboard components. These are not jumpers! Do not place jumper caps on the fan connectors!

5. ATX power connectors (20-pin ATXPWR, 4-pin ATX12V)

These connectors are for ATX power supply plugs. The power supply plugs are designed to fit these connectors in only one orientation. Find the proper orientation and push down firmly until the connectors completely fit.



Do not forget to connect the 4-pin ATX +12 V power plug; otherwise, the system will not boot up.

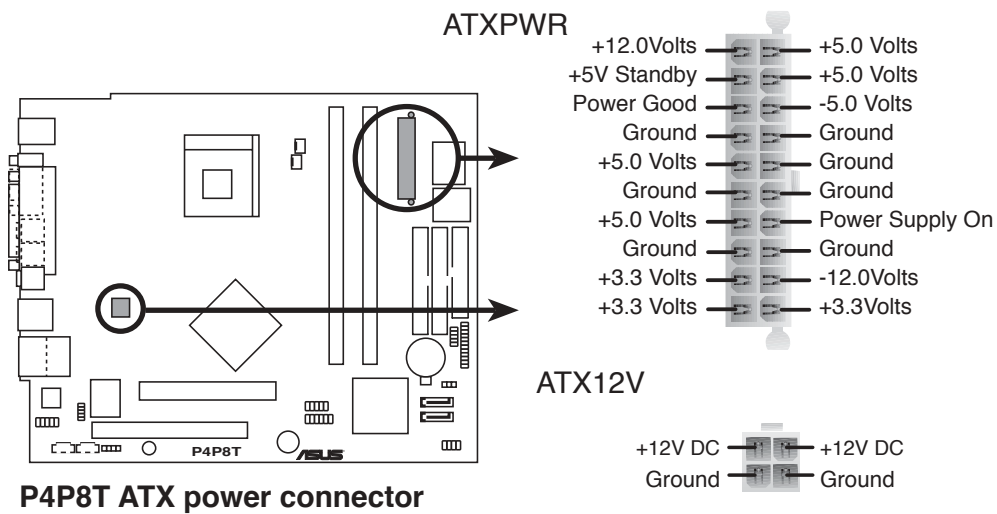

6. IDE connectors (40-1 pin PRI_IDE, SEC_IDE)

These connectors are for Ultra DMA 100/66 signal cables. The Ultra DMA 100/66 signal cable has three connectors: a blue connector for the primary IDE connector on the motherboard, a black connector for an Ultra DMA 100/66 IDE slave device (optical drive/hard disk drive), and a gray connector for an Ultra DMA 100/66 IDE master device (hard disk drive). If you install two hard disk drives, you must configure the second drive as a slave device by setting its jumper accordingly. Refer to the hard disk documentation for the jumper settings.



- Pin 20 on the IDE connector is removed to match the covered hole on the Ultra DMA cable connector. This prevents incorrect insertion when you connect the IDE cables.
- Use the 80-conductor IDE cable for Ultra DMA 100/66 IDE devices.

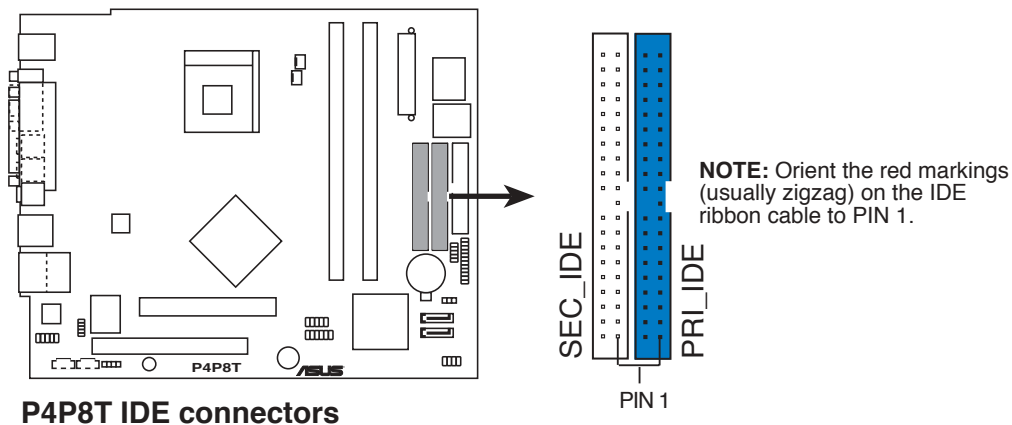

7. Internal audio connectors (4-pin AUX1, CD1)

These connectors allow you to receive stereo audio input from sound sources such as a CD-ROM, TV tuner, or MPEG card.

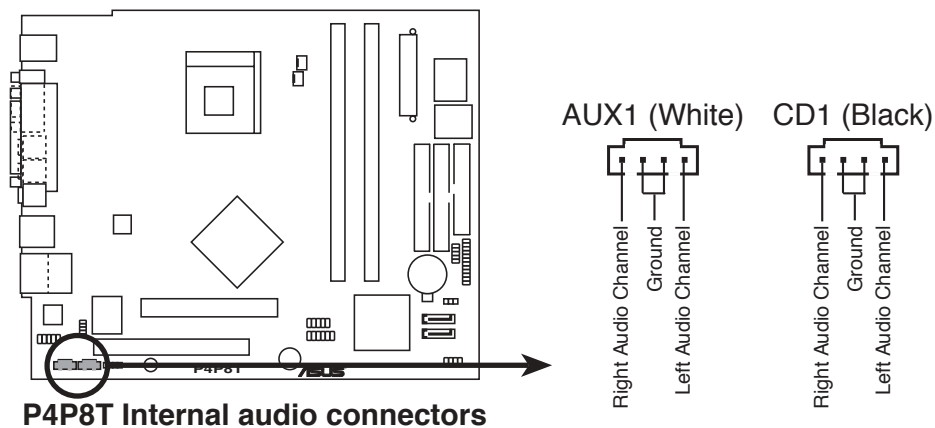

8. Serial ATA connectors (7-pin SATA2, SATA1)

These connectors are for the Serial ATA signal cables for Serial ATA hard disk drives.

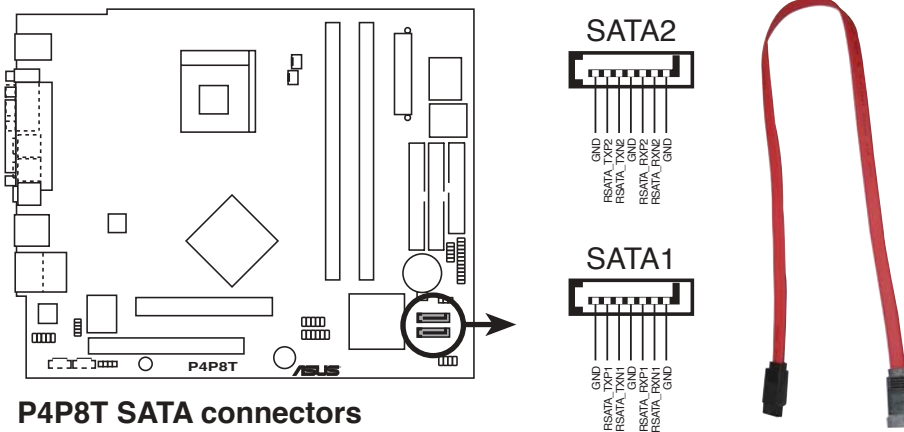

P4P8T SATA connectors



You must install Windows® 2000 Service Pack 4 or the Windows® XP Service Pack 1 before using Serial ATA hard disk drives. The Serial ATA RAID feature (RAID 0, RAID 1) is available only if you are using Windows® 2000/XP.

Parallel ATA and Serial ATA device configurations

Following are the Parallel ATA and Serial ATA device configurations supported by Intel ICH5 specifications.

Native operating systems (OS) are Windows® 2000/XP. ICH5 supports a maximum of six (6) devices using these OS.

Legacy OS are MS-DOS, Windows® 98/ME/NT4.0. ICH5 supports a maximum of four (4) devices using these OS.

Operating System	P-ATA		S-ATA	
	Primary (2 devices)	Secondary (2 devices)	Port 0 (1 device)	Port 1 (1 device)
1. Windows® 2000/XP	✓	✓	✓	✓
2. Windows® 98/Me/NT 4.0				
Configuration A	✓	—	✓	✓
Configuration B	—	✓	✓	✓
Configuration C	✓	✓	—	—

Legend: ✓ Supported — Disabled

Required IDE Configuration settings in BIOS

Refer to the following table for the appropriate BIOS settings of the above P-ATA and S-ATA device configurations. See section “5.3. 5 IDE Configuration” for details on the related BIOS items.

BIOS item	Windows®	Windows® 98/ME/NT4.0		
	2000/XP	A	B	C
Onboard IDE Operate Mode	Enhanced Mode	Compatible Mode	Compatible Mode	Compatible Mode
Enhanced Mode Support On	S-ATA	—	—	—
IDE Port Settings	—	Primary P-ATA+S-ATA	Sec. P-ATA+S-ATA	P-ATA Ports Only

9. J1 connector (10-1-pin J1)

This connector is for the card reader module on the front panel to support a Compact Flash card.

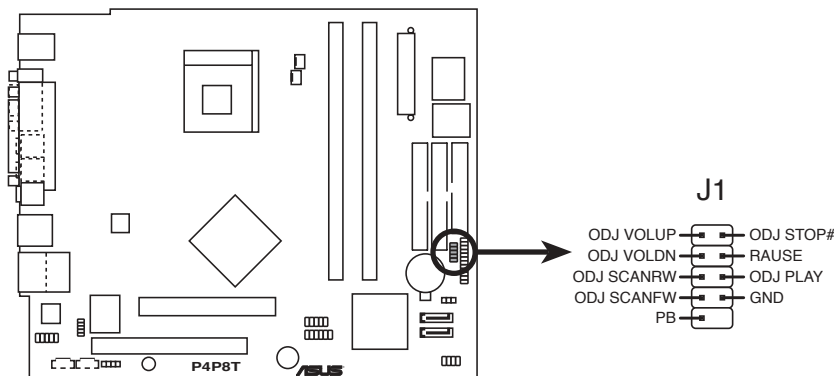

P4P8T J1 connector

10. LCD panel connector (24-1-pin LCD_PANEL)

This connector is for the LCD panel on the front panel of the S1-P111 model.

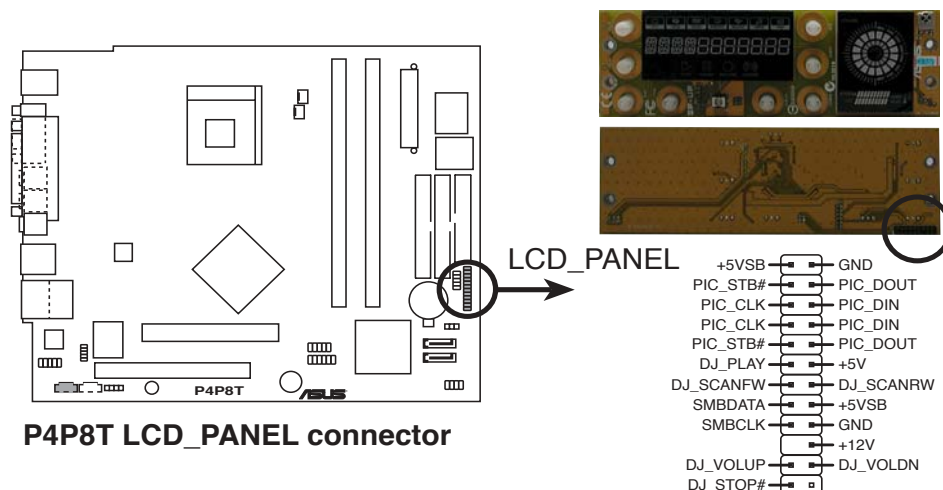

P4P8T LCD_PANEL connector

11. System panel connector (8-1 pin PANEL)

This connector accommodates several system front panel functions.

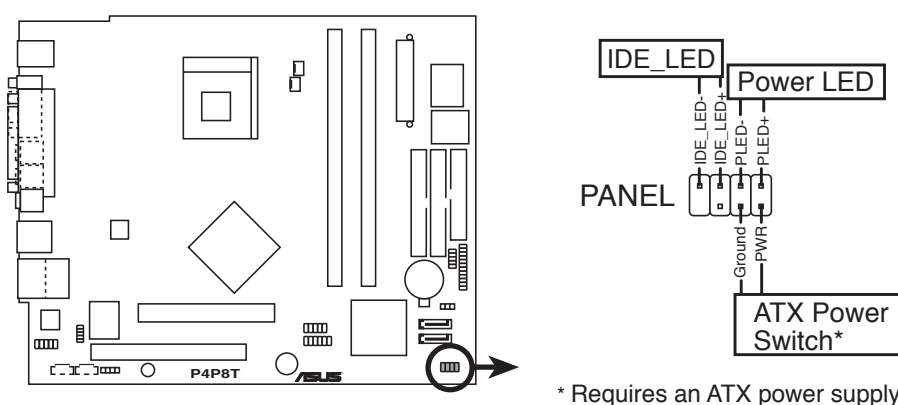

P4P8T System panel connector

* Requires an ATX power supply.

- **System power LED (2-pin PLED)**

This 3-pin connector is for the system power LED. Connect the chassis power LED cable to this connector. The system power LED lights up when you turn on the system power, and blinks when the system is in sleep mode.

- **Hard disk drive activity LED (2-pin IDE_LED)**

This 2-pin connector is for the HDD Activity LED. Connect the HDD Activity LED cable to this connector. The IDE LED lights up or flashes when data is read from or written to the HDD.

- **ATX power button/soft-off button (2-pin PWR)**

This connector is for the system power button. Pressing the power button turns the system on or puts the system in sleep or soft-off mode depending on the BIOS settings. Pressing the power switch for more than four seconds while the system is ON turns the system OFF.

Chapter 4

This chapter tells how to change system settings through the BIOS Setup menus and describes the BIOS parameters.

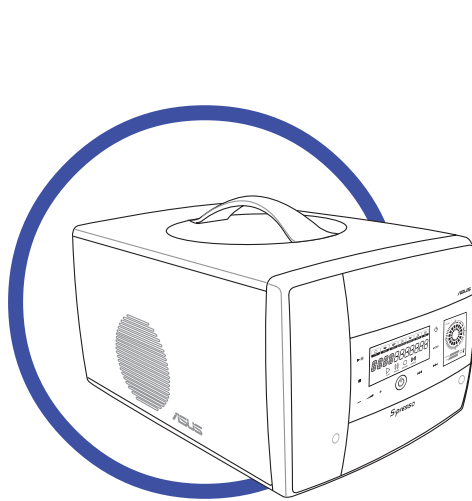

ASUS S-presso barebone system

4.1 Managing and updating your BIOS

The following utilities allow you to manage and update the motherboard Basic Input/Output System (BIOS) setup.



You need a USB floppy disk drive for utilities that require a floppy disk. If you do not have a USB floppy disk drive, you can recover the BIOS using the support CD. Proceed to page 4-8 for details.

1. **AFUDOS** (*Updates the BIOS in DOS mode using a bootable floppy disk.*)
2. **ASUS EZ Flash** (*Updates the BIOS using a floppy disk during POST.*)
3. **CrashFree BIOS 2** (*Updates the BIOS using a bootable floppy disk or the support CD when the BIOS gets corrupted.*)
4. **ASUS Update** (*Updates the BIOS in Windows® environment.*)

Refer to the corresponding section for each utility.



-
- We recommend that you save a copy of the **original motherboard BIOS file** to a **bootable floppy disk** in case you need to restore the BIOS in the future. Copy the original motherboard BIOS using the AFUDOS or the ASUS Update utilities.
 - A **working BIOS file** for this motherboard is in the support CD. Use this file only when you do not have a copy of the original motherboard BIOS file in a floppy disk.
 - Visit the ASUS website and download the latest BIOS file for this motherboard using the ASUS Update utility.
-

4.1.1 Creating a bootable floppy disk

1. Do either one of the following to create a bootable floppy disk.
DOS environment
 - a. Insert a 1.44 MB floppy disk into the drive.
 - b. At the DOS prompt, type **format A:/S** , then press <Enter>.**Windows® XP environment**
 - a. Insert a 1.44 MB floppy disk into the floppy disk drive.
 - b. From your Windows desktop, click on **Start**, then select **My Computer**.
 - c. Select the **3 1/2 Floppy Drive** icon.
 - d. Click **File** from the menu, then select **Format**. A **Format 3 1/2 Floppy Disk** window appears.
 - e. Select **Create an MS-DOS startup disk** from the format options field, then click **Start**.

2. Copy the original (or the latest) motherboard BIOS to the bootable floppy disk.

4.1.2 Using AFUDOS to copy the current BIOS

The AFUDOS.EXE utility can also be used to copy the current system BIOS settings to a floppy or hard disk. The copy can be used as a backup in case the system BIOS fails or gets corrupted.

1. At the DOS prompt, type the command line:

afudos /o<filename>

where “filename” can be any user provided filename of not more than eight (8) alpha-numeric characters for the main filename and three (3) alpha-numeric characters for the extension name.

Press <Enter>.



The BIOS information on the screen is for reference only. What you see on your screen may not be exactly the same as shown.

Main filename Extension name

```
A:\>afudos /oMYBIOS03.rom
AMI Firmware Update Utility - Version 1.10
Copyright (C) 2002 American Megatrends, Inc. All rights
reserved.

Reading flash ..... 0x0008CC00 (9%)
```

2. The utility will copy the current system BIOS by default to the floppy disk. Make sure that the floppy disk is not write-protected and have enough space (at least 600 KB) to store the file.

```
A:\>afudos /oMYBIOS03.rom
AMI Firmware Update Utility - Version 1.10
Copyright (C) 2002 American Megatrends, Inc. All rights
reserved.

Reading flash ..... done

A:\>
```

When the BIOS copy process is complete, the utility returns to the DOS prompt.

4.1.3 Using AFUDOS to update the BIOS

The AFUDOS is a DOS-based application that lets you update the BIOS file using a bootable floppy diskette. AFUDOS also allows you to copy the original BIOS file to a floppy diskette.

To update the BIOS using the AFUDOS.EXE:

1. Visit the ASUS website (www.asus.com) to download the latest BIOS file for your motherboard. Save the BIOS file to a bootable floppy disk.



Write down the BIOS file name to a piece of paper. You need to type the **exact BIOS file name** at the prompt.

2. Copy the AFUDOS.EXE utility from the support CD to the bootable floppy disk that contains the BIOS file.
3. Boot the system from the floppy disk.
4. At the DOS prompt, type the command line:

afudos /i<filename.rom>

where “filename.rom” means the latest (or original) BIOS file that you copied to the bootable floppy disk.

The screen displays the status of the update process.



The BIOS information on the screen is for reference only. What you see on your screen may not be exactly the same as shown.

```
A:\>afudos /ip4p8t.rom
AMI Firmware Update Utility - Version 1.10
Copyright (C) 2002 American Megatrends, Inc. All rights
reserved.

Reading file ..... done
Erasing flash .... done
Writing flash .... 0x0008CC00 (9%)
```



DO NOT shut down or reset the system while updating the BIOS! Doing so may cause system boot failure!

When the BIOS update process is complete, the utility returns to the DOS prompt.

```
A:\>afudos /ip4p8t.rom
AMI Firmware Update Utility - Version 1.10
Copyright (C) 2002 American Megatrends, Inc. All rights
reserved.

    Reading file ..... done
    Erasing flash .... done
    Writing flash .... 0x0008CC00 (9%)
    Verifying flash .. done

A:\>
```

5. Reboot the system from the hard disk.

4.1.4 Using ASUS EZ Flash to update the BIOS

The ASUS EZ Flash feature allows you to easily update the BIOS without having to go through the long process of booting from a floppy disk and using a DOS-based utility. The EZ Flash is built-in the BIOS LPC chip so it is accessible by simply pressing <Alt> + <F2> during the Power-On Self Tests (POST).

To update the BIOS using ASUS EZ Flash:

1. Visit the ASUS website (www.asus.com) to download the latest BIOS file for your motherboard and rename it to **P4P8T.ROM**. Save the BIOS file to a floppy disk.
2. Reboot the system.
3. To launch EZ Flash, press <Alt> + <F2> during POST to display the following.

```
User recovery requested. Starting BIOS recovery...
Checking for floppy...
```



- If no floppy disk found in the drive, the error message “**Floppy not found!**” appears.
- If the correct BIOS file is not found in the floppy disk, the error message “**P4P8T.ROM not found!**” appears.

4. Insert the floppy disk that contains the BIOS file. If the **P4P8T.ROM** file is found in the floppy disk, EZ Flash performs the BIOS update process and automatically reboots the system when done.



DO NOT shut down or reset the system while updating the BIOS! Doing so may cause system boot failure!

```
User recovery requested. Starting BIOS recovery...
Checking for floppy...
Floppy found!
Reading file "p4p8t.rom". Completed.
Start flashing...
Flashed successfully. Rebooting.
```

4.1.5 Recovering the BIOS with CrashFree BIOS 2

The CrashFree BIOS 2 auto recovery tool allows you to restore BIOS from the motherboard support CD, or from a floppy disk that contains the BIOS file, in case the current BIOS on the motherboard fails or gets corrupted.



- Prepare the **support CD** that came with the motherboard or a **floppy disk that contains the motherboard BIOS** (P4P8T.ROM) before proceeding with the BIOS update process.
- If you have saved a copy of the original motherboard BIOS to a bootable floppy disk, you may also use this disk to restore the BIOS. See section “5.1.1 Creating a bootable floppy disk.”

To recover the BIOS from a floppy disk:

1. Boot the system.
2. When a corrupted BIOS is detected, the following message appears.

```
Bad BIOS checksum. Starting BIOS recovery...
Checking for floppy...
```

3. Insert a floppy disk that contains the original, or the latest, BIOS file for this motherboard (**P4P8T.ROM**). If the BIOS file that you downloaded from the ASUS website has a different filename (e.g. **P4P8T11.ROM**), rename it to **P4P8T.ROM**. The BIOS update process continues when the **P4P8T.ROM** is found.

```
Bad BIOS checksum. Starting BIOS recovery...
Checking for floppy...
Floppy found!
Reading file "p4p8t.rom". Completed.
Start flashing...
```



DO NOT shut down or reset the system while updating the BIOS! Doing so may cause system boot failure!

4. When the BIOS update process is complete, reboot the system.

To recover the BIOS from the support CD:

1. Boot the system.
2. When a corrupted BIOS is detected, the following screen message appears.

```
Bad BIOS checksum. Starting BIOS recovery...  
Checking for floppy...
```



The system automatically checks the CD-ROM if there is no floppy disk found in the drive.

3. Place the support CD in the optical drive. The support CD contains the original BIOS for this motherboard.

```
Bad BIOS checksum. Starting BIOS recovery...  
Checking for floppy...  
Floppy not found!  
Checking for CD-ROM...  
CD-ROM found.  
Reading file "p4p8t.rom". Completed.  
Start flashing...
```



DO NOT shut down or reset the system while updating the BIOS! Doing so may cause system boot failure!

4. When the BIOS update process is complete, reboot the system.



The recovered BIOS may not be the latest BIOS version for this motherboard. Visit the ASUS website (www.asus.com) to download the latest BIOS file.

4.1.6 ASUS Update

The ASUS Update is a utility that allows you to update the motherboard BIOS in Windows® environment. This utility is available in the support CD that comes with the motherboard package. ASUS Update requires an Internet connection either through a network or an Internet Service Provider (ISP).

To install ASUS Update:

1. Place the support CD in the optical drive. The **Drivers** menu appears.
2. Click the **Utilities** tab, then click **Install ASUS Update VX.XX.XX**. See page 5-5 for the **Utilities** menu screen.
3. The ASUS Update utility is copied into your system.

To update the BIOS using the ASUS Update:

1. Launch the utility from the Windows desktop by clicking **Start > Programs > ASUS > ASUSUpdate > ASUSUpdate**. The ASUS Update initial screen appears.
2. Select your desired update method, then click **Next**.

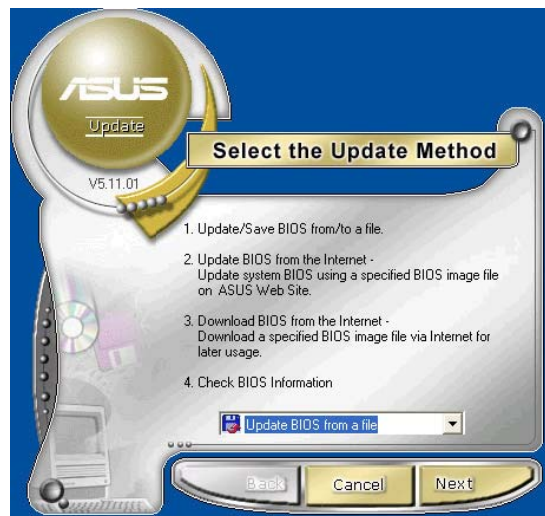

3. If you selected updating/downloading from the Internet, select the ASUS FTP site nearest you to avoid network traffic, or choose **Auto Select**. Click **Next**.

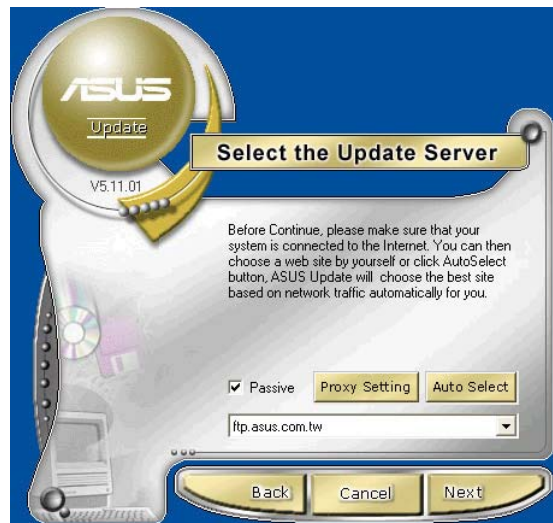

4. From the FTP site, select the BIOS version that you wish to download. Click **Next**.
5. Follow the screen instructions to complete the update process.

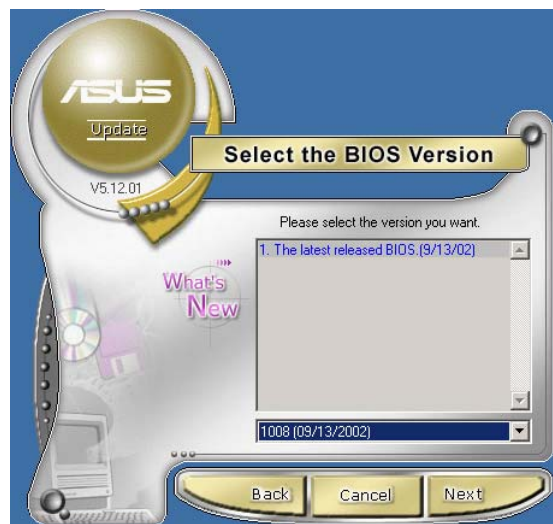

If you selected the option to update the BIOS from a file, a window pops up prompting you to locate the file. Select the file, click **Save**, then follow the screen instructions to complete the update process.

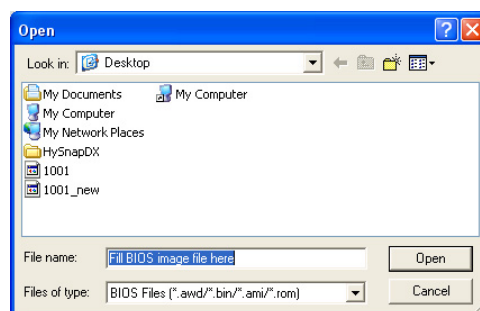

4.2 BIOS Setup program

This motherboard supports a programmable Firmware Hub (FWH) that you can update using the provided utility described in section “4.1 Managing and updating your BIOS.”

Use the BIOS Setup program when you are installing a motherboard, reconfiguring your system, or prompted to “Run Setup.” This section explains how to configure your system using this utility.

Even if you are not prompted to use the Setup program, you may want to change the configuration of your computer in the future. For example, you may want to enable the security password feature or make changes to the power management settings. This requires you to reconfigure your system using the BIOS Setup program so that the computer can recognize these changes and record them in the CMOS RAM of the firmware hub.

The firmware hub stores the Setup utility. When you start up the computer, the system provides you with the opportunity to run this program. Press <Delete> during the Power-On Self Test (POST) to enter the Setup utility, otherwise, POST continues with its test routines.

If you wish to enter Setup after POST, restart the system by pressing <Ctrl> + <Alt> + <Delete>, or by pressing the reset button on the system chassis. You can also restart by turning the system off and then back on. Do this last option only if the first two failed.

The Setup program is designed to make it as easy to use as possible. It is a menu-driven program, which means you can scroll through the various sub-menus and make your selections among the predetermined choices.



Because the BIOS software is constantly being updated, the following BIOS setup screens and descriptions are for reference purposes only, and may not exactly match what you see on your screen.

4.2.1 BIOS menu screen

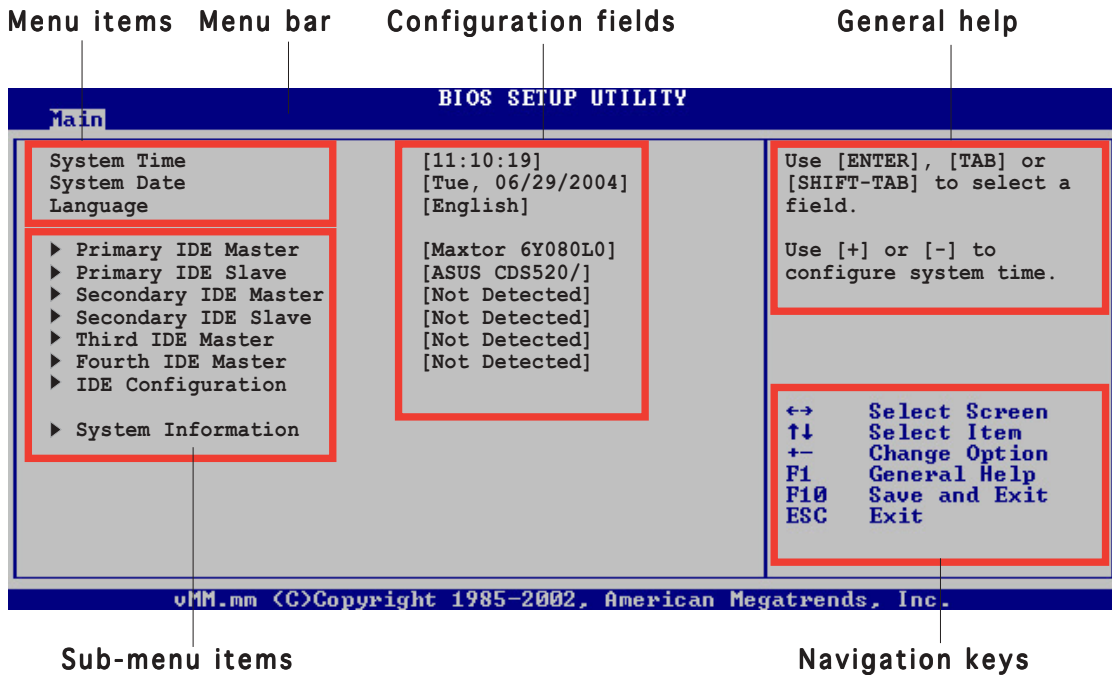

4.2.2 Menu bar

The menu bar on top of the screen has the following main items:

- Main** For changing the basic system configuration
- Advanced** For changing the advanced system settings
- Power** For changing the advanced power management (APM) configuration
- Boot** For changing the system boot configuration
- Exit** For selecting the exit options and loading default settings

To select an item on the menu bar, press the right or left arrow key on the keyboard until the desired item is highlighted.

4.2.3 Navigation keys

At the **bottom right corner** of a menu screen are the navigation keys for that particular menu. Use the navigation keys to select items in the menu and change the settings.



Some of the navigation keys differ from one screen to another.

4.2.4 Menu items

The highlighted item on the menu bar displays the specific items for that menu. For example, selecting **Main** shows the Main menu items.

The other items (Advanced, Power, Boot, and Exit) on the menu bar have their respective menu items.

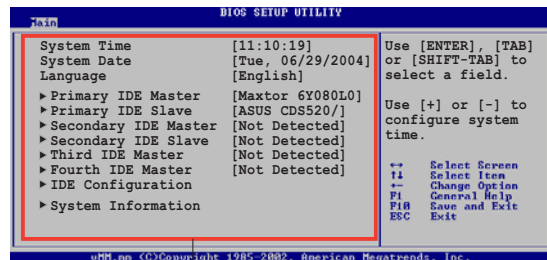

Main menu items

4.2.5 Sub-menu items

An item with a sub-menu on any menu screen is distinguished by a solid triangle before the item. To display the sub-menu, select the item and press <Enter>.

4.2.6 Configuration fields

These fields show the values for the menu items. If an item is user-configurable, you may change the value of the field opposite the item. You can not select an item that is not user-configurable.

A configurable field is enclosed in brackets, and is highlighted when selected. To change the value of a field, select it then press Enter to display a list of options. Refer to “4.2.7 Pop-up window.”

4.2.7 Pop-up window

Select a menu item then press <Enter> to display a pop-up window with the configuration options for that item.

4.2.8 Scroll bar

A scroll bar appears on the right side of a menu screen when there are items that do not fit on the screen. Press **Up/Down arrow keys** or **PageUp/PageDown keys** to display the other items on the screen.

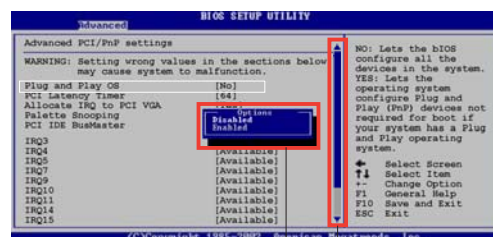

Pop-up window

Scroll bar

4.2.9 General help

At the top right corner of the menu screen is a brief description of the selected item.

4.3 Main menu

When you enter the BIOS Setup program, the Main menu screen appears giving you an overview of the basic system information.



Refer to section “4.2.1 BIOS menu screen” for information on the menu screen items and how to navigate through them.

```
BIOS SETUP UTILITY
Main
System Time          [11:10:19]
System Date          [Tue, 06/29/2004]
Language             [English]
Use [ENTER], [TAB] or [SHIFT-TAB] to select a field.

▶ Primary IDE Master [Maxtor 6Y080L0]
▶ Primary IDE Slave  [ASUS CDS520/]
▶ Secondary IDE Master [Not Detected]
▶ Secondary IDE Slave [Not Detected]
▶ Third IDE Master    [Not Detected]
▶ Fourth IDE Master   [Not Detected]
▶ IDE Configuration

▶ System Information

Use [+] or [-] to configure system time.

↔ Select Screen
↑↓ Select Item
+- Change Option
F1 General Help
F10 Save and Exit
ESC Exit

vMM.mm <C>Copyright 1985-2002, American Megatrends, Inc.
```

4.3.1 System Time [xx:xx:xxxx]

Allows you to set the system time.

4.3.2 System Date [Day xx/xx/xxxx]

Allows you to set the system date.

4.3.3 Primary and Secondary IDE Master/Slave; Third and Fourth IDE Master

While entering Setup, BIOS auto-detects the presence of IDE devices. There is a separate sub-menu for each IDE device. Select a device item then press <Enter> to display the IDE device information.

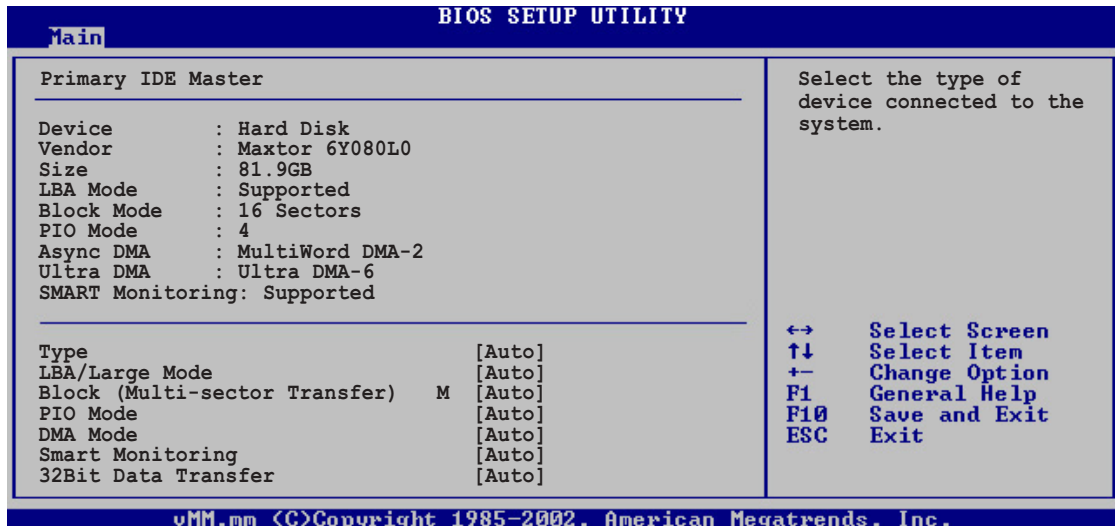

The values opposite the dimmed items (Device, Vendor, Size, LBA Mode, Block Mode, PIO Mode, Async DMA, Ultra DMA, and SMART monitoring) are auto-detected by BIOS and are not user-configurable. These items show N/A if no IDE device is installed in the system.

Type [Auto]

Selects the type of IDE drive. Setting to Auto allows automatic selection of the appropriate IDE device type. Select CDROM if you are specifically configuring a CD-ROM drive. Select ARMD (ATAPI Removable Media Device) if your device is either a ZIP, LS-120, or MO drive.

Configuration options: [Not Installed] [Auto] [CDROM] [ARMD]

LBA/Large Mode [Auto]

Enables or disables the LBA mode. Setting to Auto enables the LBA mode if the device supports this mode, and if the device was not previously formatted with LBA mode disabled. Configuration options: [Disabled] [Auto]

Block (Multi-sector Transfer) [Auto]

Enables or disables data multi-sectors transfers. When set to Auto, the data transfer from and to the device occurs multiple sectors at a time if the device supports multi-sector transfer feature. When set to Disabled, the data transfer from and to the device occurs one sector at a time.

Configuration options: [Disabled] [Auto]

PIO Mode [Auto]

Selects the PIO mode. Configuration options: [Auto] [0] [1] [2] [3] [4]

DMA Mode [Auto]

Selects the DMA mode. Configuration options: [Auto] [SWDMA0] [SWDMA1] [SWDMA2] [MWDMA0] [MWDMA1] [MWDMA2] [UDMA0] [UDMA1] [UDMA2] [UDMA3] [UDMA4] [UDMA5]

SMART Monitoring [Auto]

Sets the Smart Monitoring, Analysis, and Reporting Technology. Configuration options: [Auto] [Disabled] [Enabled]

32Bit Data Transfer [Disabled]

Enables or disables 32-bit data transfer. Configuration options: [Disabled] [Enabled]

4.3.4 IDE Configuration

The items in this menu allow you to set or change the configurations for the IDE devices installed in the system. Select an item then press <Enter> to configure the item.

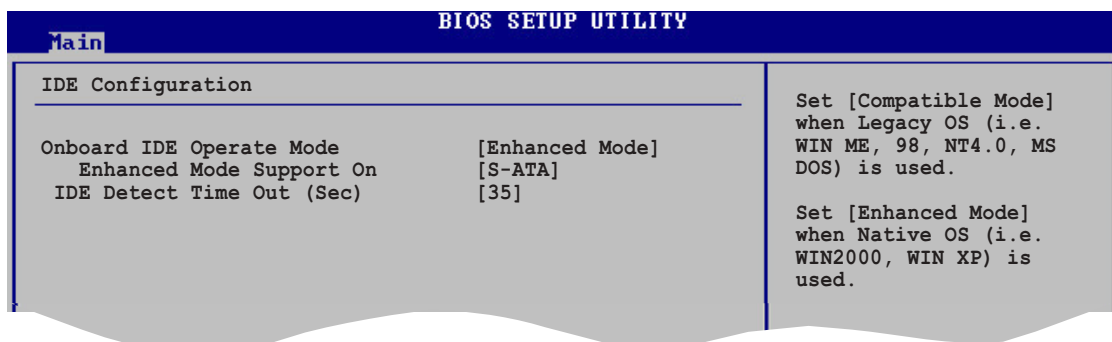

Onboard IDE Operate Mode [Enhanced Mode]

Allows selection of the IDE operation mode depending on the operating system (OS) that you installed. Set to Enhanced Mode if you are using native OS, such as Windows® 2000/XP. Set to Compatible Mode if you are using legacy OS including MS-DOS, Windows® ME/98/NT4.0.

Configuration options: [Compatible Mode] [Enhanced Mode]



Refer to the “Parallel ATA and Serial ATA device configuration” section on page 3-9 for correct IDE configuration settings in different operating systems.

Enhanced Mode Support On [S-ATA]

The default setting S-ATA allows you to use native OS on Serial ATA and Parallel ATA ports. We recommend that you do not change the default setting for better OS compatibility. In this setting, you may use legacy OS on the Parallel ATA ports **only if** you did not install any Serial ATA device.

The P-ATA+S-ATA and P-ATA options are for advanced users only. If you set to any of these options and encounter problems, revert to the default setting **S-ATA**. Configuration options: [P-ATA+S-ATA] [S-ATA] [P-ATA]

IDE Detect Time Out [35]

Selects the time out value for detecting ATA/ATAPI devices.
Configuration options: [0] [5] [10] [15] [20] [25] [30] [35]

4.3.5 System Information

This menu gives you an overview of the general system specifications. The BIOS auto-detects the items in this menu.

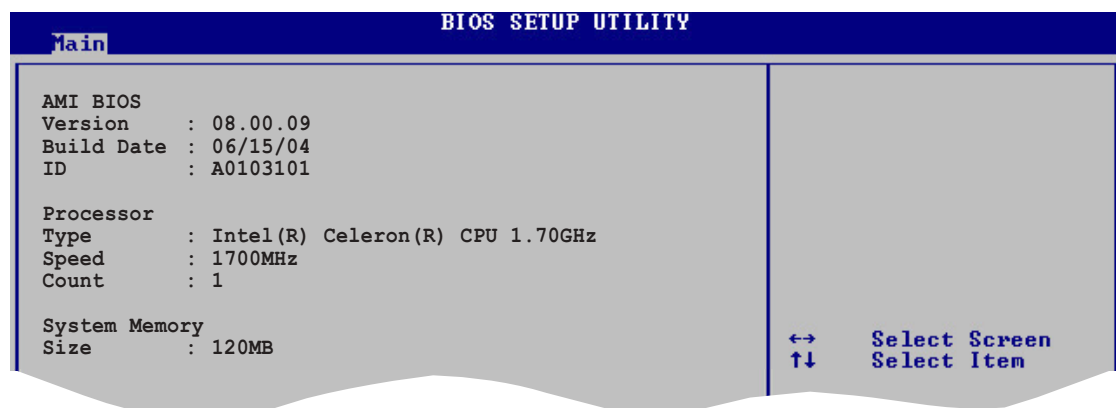

AMI BIOS

This item displays the auto-detected BIOS information.

Processor

This item displays the auto-detected CPU specification.

System Memory

This item displays the auto-detected system memory.

4.4 Advanced menu

The Advanced menu items allow you to change the settings for the CPU and other system devices.



Take caution when changing the settings of the Advanced menu items. Incorrect field values may cause the system to malfunction.

```

Main  Advanced  Power  BIOS SETUP UTILITY
      Boot    Exit
-----
▶ CPU Configuration          Configure CPU.
▶ Chipset
▶ Onboard Devices Configuration
▶ PCI PnP
▶ USB Configuration

Load MiniLoader             [Disabled]

←→  Select Screen
↑↓  Select Item
Enter Go to Sub Screen
F1   General Help
F10  Save and Exit
ESC  Exit

vMM.mm (C)Copyright 1985-2002, American Megatrends, Inc.

```

4.4.1 CPU Configuration

The items in this menu show the CPU-related information auto-detected by BIOS.

```

Advanced  BIOS SETUP UTILITY
-----
Configure advanced CPU settings

Manufacturer : Intel(R)
Brand String : Intel(R) Celeron(R) 4 CPU 1.70GHz
Frequency    : 1700MHz
FSB Speed    : 400MHz

Cache L1     : 8 KB
Cache L2     : 128 KB
Cache L3     : 0 KB

Ratio Status : Locked
Ratio Actual Value : 17
Max CPUID Value Limit [Disabled]

Sets the ration
between CPU Core Clock
and the FSB Freuency.

Note: If an invalid
ratio is set in CMOS,
then actual and
setpoint values may
differ.

←→  Select Screen
↑↓  Select Item
+-  Change Option
F1   General Help
F10  Save and Exit
ESC  Exit

vMM.mm (C)Copyright 1985-2002, American Megatrends, Inc.

```

Max CPUID Value Limit [Disabled]

Allows you to enable or disable the CPUID maximum value limit support for older OS. Configuration options: [Disabled] [Enabled]

4.4.2 Chipset

The Chipset menu items allow you to change the advanced chipset settings. Select an item then press <Enter> to display the sub-menu.

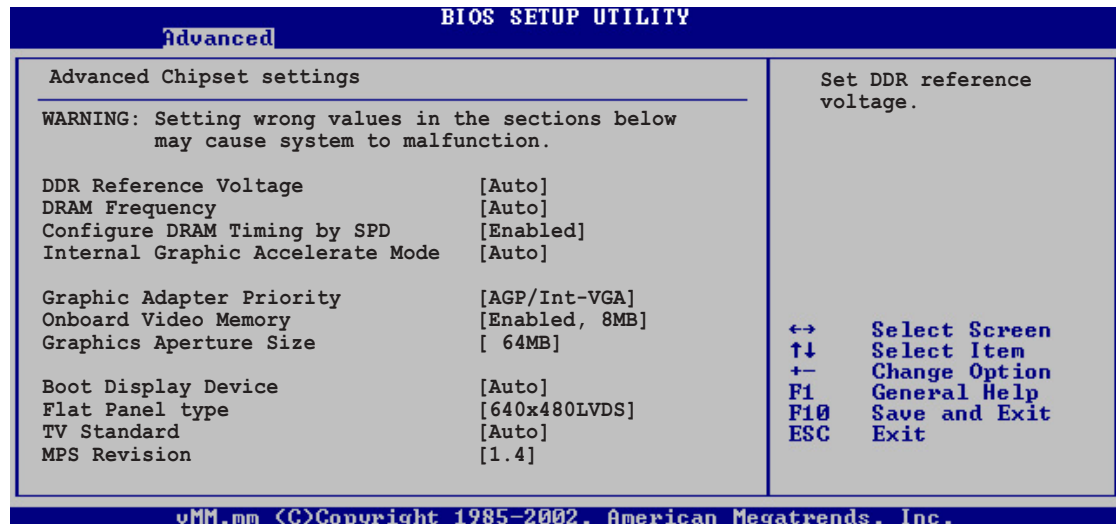

DDR Reference Voltage [Auto]

Allows you to set the DDR reference voltage. We recommend that you keep the default setting [Auto]. Configuration options: [Auto] [2.60V] [2.70V]

DRAM Frequency [Auto]

Allows you to set the DRAM frequency. We recommend that you keep the default setting [Auto]. Configuration options: [266MHz] [333MHz] [400MHz] [Auto]

Configure DRAM Timing by SPD [Enabled]

When this item is enabled, the DRAM timing parameters are set according to the DRAM SPD (Serial Presence Detect). Configuration options: [Disabled] [Enabled]

The following sub-items appear when this item is Disabled.

DRAM CAS# Latency [2.5 Clocks]

This item controls the latency between the SDRAM read command and the time the data actually becomes available.

Configuration options: [2.0 Clocks] [2.5 Clocks] [3.0 Clocks]

DRAM RAS# Precharge [4 Clocks]

This item controls the idle clocks after issuing a precharge command to the DDR SDRAM. Configuration options: [4 Clocks] [3 Clocks] [2 Clocks]

DRAM RAS# to CAS# Delay [4 Clocks]

This item controls the latency between the DDR SDRAM active command and the read/write command.

Configuration options: [4 Clocks] [3 Clocks] [2 Clocks]

DRAM Precharge Delay [8 Clocks]

Configuration options: [8 Clocks] [7 Clocks] [6 Clocks] [5 Clocks]

DRAM Burst Length [8 Clocks]

Configuration options: [4 Clocks] [8 Clocks]

Internal Graphic Accelerate Mode [Auto]

Allows you to select the internal graphic acceleration mode.

Configuration options: [2T] [1T] [Auto]

Graphic Adapter Priority [AGP/Int-VGA]

This option allows you to select the graphics controller to use as primary boot device. Configuration options: [Internal VGA] [AGP/PCI] [PCI/AGP] [PCI/Int-VGA]

Onboard Video Memory [Enabled, 8MB]

Allows you to set the size of the onboard video memory.

Configuration options: [Disabled] [Enabled, 1MB] [Enabled, 4MB] [Enabled, 8MB] [Enabled, 16MB] [Enabled, 32MB]

Graphics Aperture Size [64MB]

Allows you to select the mapped memory for AGP graphic data.

Configuration options: [4MB] [8MB] [16MB] [32MB] [64MB] [128MB] [256MB]

Boot Display Device [Auto]

Allows you to select the boot display device.

Configuration options: [Auto] [CRT] [TV] [EFP] [LFP] [CRT+EFP] [CRT+LFP]

Flat Panel Display [640x480LVDS]

Allows you to select the flat panel display resolution when you selected LCD Flat Panel [LFP] as your boot display device.

Configuration options: [640x480LVDS] [800x600LVDS] [1024x768LVDS] [1280x1024LVDS] [1400x1050LVDS] [1600x1200LVDS] [640x480CMOS] [800x600CMOS] [1024x768CMOS] [1280x1024CMOS] [1400x1050CMOS] [1600x1200CMOS]

TV Standard [Auto]

Allows you to select the TV standard when you selected TV as your boot display device. Configuration options: [Auto] [NTSC_M] [NTSC_M_J] [NTSC_433] [NTSC_N] [PAL_B] [PAL_G] [PAL_D] [PAL_H] [PAL_I] [PAL_M] [PAL_N] [PAL_60] [SECAM_L] [SECAM_L1] [SECAM_B]

MPS Revision [1.4]

Configuration options: [1.4] [1.1]

4.4.3 Onboard Devices Configuration

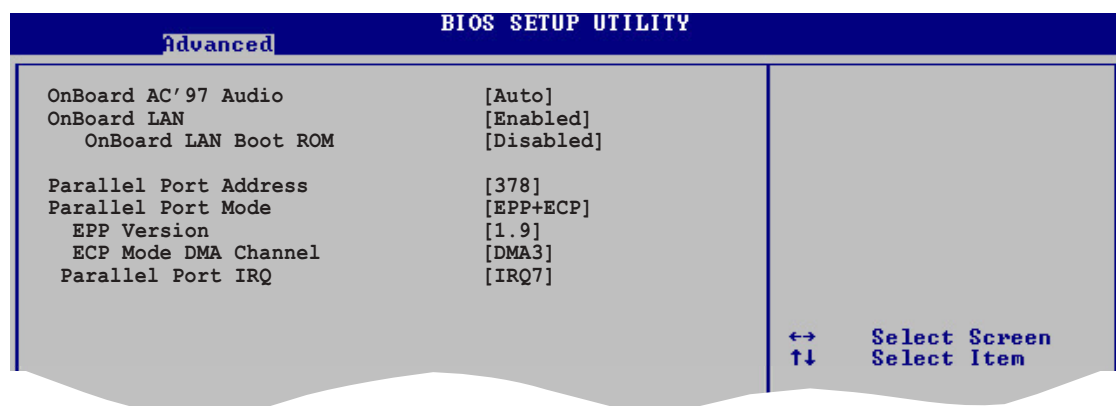

OnBoard AC'97 Audio [Auto]

[Auto] allows the BIOS to detect whether you are using any audio device. If an audio device is detected, the onboard audio controller is enabled; if no audio device is detected, the controller is disabled.

Configuration options: [Auto] [Disabled]

OnBoard LAN [Enabled]

Allows you to enable or disable the onboard LAN controller.

Configuration options: [Enabled] [Disabled]

OnBoard LAN Boot ROM [Disabled]

Allows you to enable or disable the option ROM in the onboard LAN controller. This item appears only when the Onboard LAN item is set to Enabled. Configuration options: [Disabled] [Enabled]

Parallel Port Address [378]

Allows you to select the Parallel Port base addresses.

Configuration options: [Disabled] [378] [278]

Parallel Port Mode [EPP+ECP]

Allows you to select the Parallel Port mode.

Configuration options: [Normal] [EPP] [ECP] [EPP+ECP]

EPP Version [1.9]

Allows selection of the Parallel Port EPP version. This item appears only when the **Parallel Port Mode** is set to **EPP** or **EPP+ECP**.

Configuration options: [1.9] [1.7]

ECP Mode DMA Channel [DMA3]

Allows selection of the Parallel Port ECP DMA channel. This item appears only when the **Parallel Port Mode** is set to **ECP** or **EPP+ECP**.

Configuration options: [DMA0] [DMA1] [DMA3]

Parallel Port IRQ [IRQ7]

Allows you to select the Parallel Port IRQ.

Configuration options: [IRQ5] [IRQ7]

4.4.4 PCI PnP

The PCI PnP menu items allow you to change the advanced settings for PCI/PnP devices. The menu includes setting IRQ and DMA channel resources for either PCI/PnP or legacy ISA devices, and setting the memory size block for legacy ISA devices.



Take caution when changing the settings of the PCI PnP menu items. Incorrect field values may cause the system to malfunction.



Plug and Play O/S [No]

When set to [No], BIOS configures all the devices in the system. When set to [Yes] and if you installed a Plug & Play operating system, the operating system configures the Plug & Play devices not required for boot. Configuration options: [No] [Yes]

PCI Latency Timer [64]

Allows you to select the value in units of PCI clocks for the PCI device latency timer register. Configuration options: [32] [64] [96] [128] [160] [192] [224] [248]

Allocate IRQ to PCI VGA [Yes]

When set to [Yes], BIOS assigns an IRQ to PCI VGA card if the card requests for an IRQ. When set to [No], BIOS does not assign an IRQ to the PCI VGA card even if requested. Configuration options: [Yes] [No]

Palette Snooping [Disabled]

When set to [Enabled], the palette snooping feature informs the PCI devices that an ISA graphics device is installed in the system so that the latter can function correctly. Setting to [Disabled] deactivates this feature. Configuration options: [Disabled] [Enabled]

PCI IDE BusMaster [Enabled]

Allows the BIOS to use PCI bus mastering when reading/writing to IDE devices. Configuration options: [Disabled] [Enabled]

IRQxx [Available]

When set to [Available], the specific IRQ is free for use of PCI/PnP devices. When set to [Reserved], the IRQ is reserved for legacy ISA devices. Configuration options: [Available] [Reserved]

4.4.5 USB Configuration

The items in this menu allow you to change the USB-related features. Select an item then press <Enter> to display the configuration options.

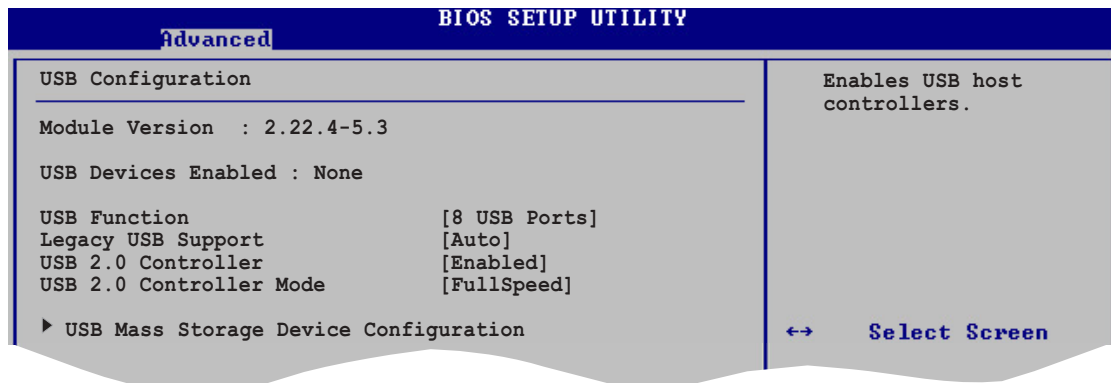

The Module Version and USB Devices Enabled items show the auto-detected values. If no USB device is detected, the item shows None.

USB Function [8 USB Ports]

Allows you to set the number of USB ports to activate. Configuration options: [Disabled] [2 USB Ports] [4 USB Ports] [6 USB Ports] [8 USB Ports]

Legacy USB Support [Auto]

Allows you to enable or disable support for legacy USB devices. Setting to Auto allows the system to detect the presence of USB devices at startup. If detected, the USB controller legacy mode is enabled. If no USB device is detected, the legacy USB support is disabled. Configuration options: [Auto] [Enabled] [Disabled]

USB 2.0 Controller [Enabled]

Allows you to enable or disable the USB 2.0 controller.
Configuration options: [Enabled] [Disabled]

USB 2.0 Controller Mode [FullSpeed]

Allows you to configure the USB 2.0 controller in HiSpeed (480 Mbps) or Full Speed (12 Mbps). Configuration options: [Full Speed] [Hi Speed]

USB Mass Storage Device Configuration

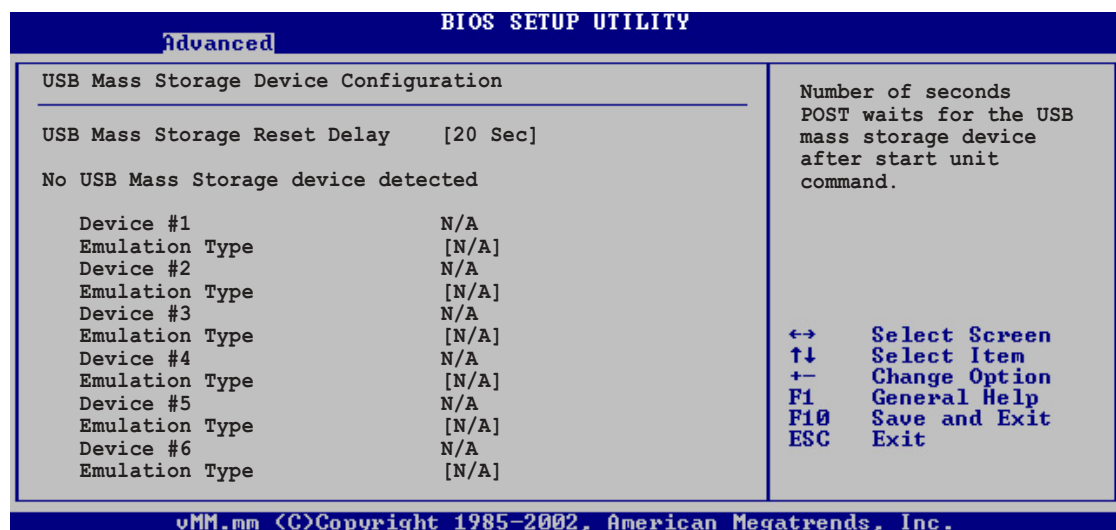

USB Mass Storage Reset Delay [20 Sec]

Allows you to select the number of seconds POST waits for the USB mass storage device after the start unit command. The message "No USB mass storage device detected" appears if none is installed in the system. Configuration options: [10 Sec] [20 Sec] [30 Sec] [40 Sec]

Emulation Type [N/A]

When set to Auto, USB devices less than 530 MB will be emulated as a floppy drive, and the remaining drives as hard drives. Forced FDD option can be used to force an HDD formatted drive to boot as FDD (for example, ZIP drive).



The Device and Emulation Type items appear only when USB storage devices are installed.

4.4.6 Load MiniLoader [Disabled]

Enable this item if you want the system to always enter Instant ON.
Configuration options: [Enabled] [Disabled]

4.5 Power menu

The Power menu items allow you to change the settings for the Advanced Power Management (APM). Select an item then press <Enter> to display the configuration options.

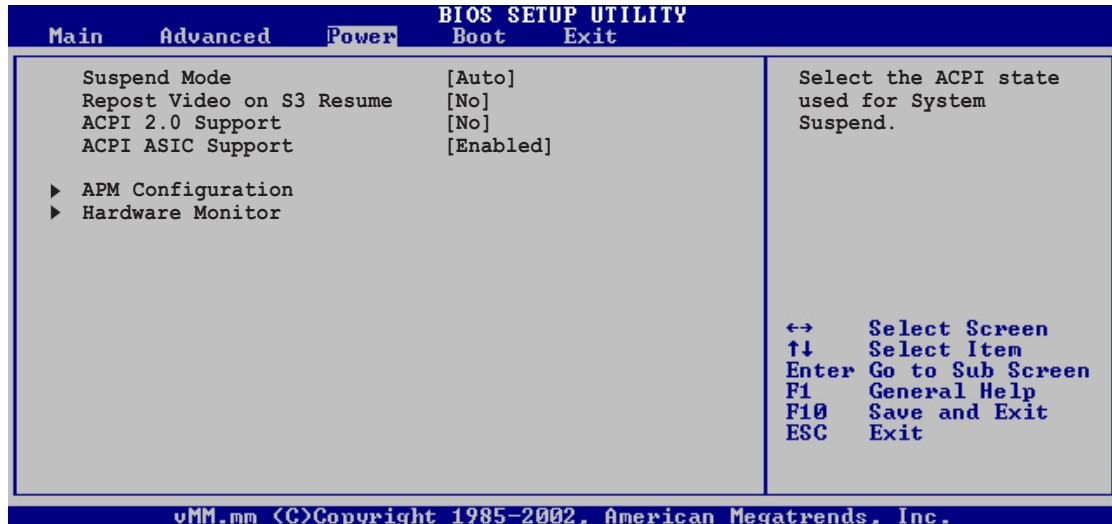

4.5.1 Suspend Mode [Auto]

Allows you to select the ACPI state to be used for system suspend.
Configuration options: [S1 (POS) Only] [S3 Only] [Auto]

4.5.2 Repost Video on S3 Resume [No]

Determines whether to invoke VGA BIOS POST on S3/STR resume.
Configuration options: [No] [Yes]

4.5.3 ACPI 2.0 Support [No]

Allows you to add more tables for ACPI 2.0 specifications.
Configuration options: [No] [Yes]

4.5.4 ACPI APIC Support [Enabled]

Allows you to enable or disable the ACPI support in the ASIC. When set to Enabled, the ACPI APIC table pointer is included in the RSDT pointer list.
Configuration options: [Disabled] [Enabled]

4.5.5 APM Configuration

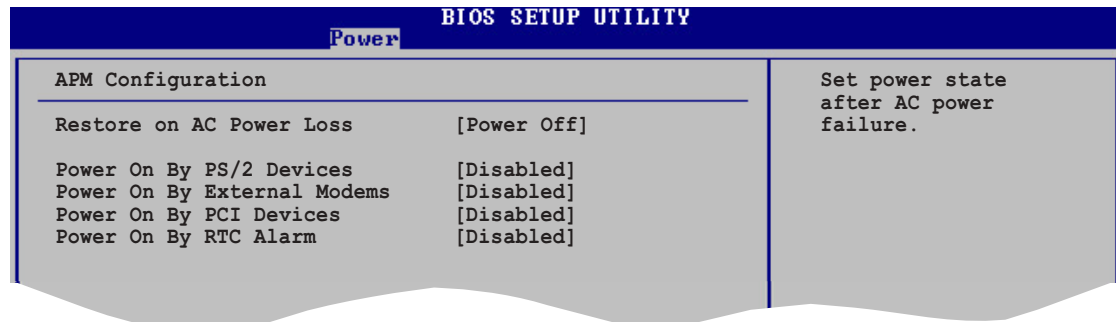

Restore on AC Power Loss [Power Off]

When set to Power Off, the system goes into off state after an AC power loss. When set to Power On, the system goes on after an AC power loss. Configuration options: [Power Off] [Power On]

Power On By PS/2 Devices [Disabled]

Allows you to use specific keys on the keyboard or the mouse to turn on the system. This feature requires an ATX power supply that provides at least 1A on the +5VSB lead. Configuration options: [Disabled] [Enabled]

Power On By External Modems [Disabled]

Allows either settings of [Enabled] or [Disabled] for powering up the computer when the external modem receives a call while the computer is in Soft-off mode. Configuration options: [Disabled] [Enabled]



The computer cannot receive or transmit data until the computer and applications are fully running. Thus, connection cannot be made on the first try. Turning an external modem off and then back on while the computer is off causes an initialization string that turns the system power on.

Power On By PCI Devices [Disabled]

When set to [Enabled], this parameter allows you to turn on the system through a PCI LAN or modem card. This feature requires an ATX power supply that provides at least 1A on the +5VSB lead. Configuration options: [Disabled] [Enabled]

Power On By RTC Alarm [Disabled]

Allows you to enable or disable RTC to generate a wake event. When this item is set to Enabled, the items RTC Alarm Date, RTC Alarm Hour, RTC Alarm Minute, and RTC Alarm Second appear with set values. Configuration options: [Disabled] [Enabled]

4.5.6 Hardware Monitor

BIOS SETUP UTILITY	
Power	
Hardware Monitor	MB temperature.
MB Temperature	[36°C/96.5°F]
CPU Temperature	[44°C/111°F]
CPU Fan Speed	[5234RPM]
Chassis Fan Speed	[N/A]
VCORE Voltage	[1.808V]
3.3V Voltage	[3.376V]
5V Voltage	[5.080V]
12V Voltage	[11.977V]
SMART Q-Fan Function	[Enabled]
	↔ Select Screen ↑↓ Select Item +− Change Option F1 General Help F10 Save and Exit ESC Exit

vMM.mm <C>Copyright 1985-2002, American Megatrends, Inc.

MB Temperature [xxx°C/xxx°F]

CPU Temperature [xxx°C/xxx°F]

The onboard hardware monitor automatically detects and displays the motherboard and CPU temperatures. Select [Disabled] if you do not want to display the detected temperatures.

CPU Fan Speed [xxxxRPM] or [Ignored]

Chassis Fan Speed [xxxxRPM] or [N/A]

The onboard hardware monitor automatically detects and displays the CPU, chassis, and power fan speeds in rotations per minute (RPM). If any of the fans is not connected to the motherboard, the specific field shows Ignored.

VCORE Voltage, +3.3V Voltage, +5V Voltage, +12V Voltage

The onboard hardware monitor automatically detects the voltage output through the onboard voltage regulators.



If any of the monitored items is out of range, the following error message appears: “Hardware Monitor found an error. Enter Power setup menu for details.” You will then be prompted to “Press F1 to continue or DEL to enter SETUP.”

SMART Q-Fan Function [Enabled]

Allows you to enable or disable the ASUS Smart Q-Fan feature that smartly adjusts the fan speeds for more efficient system operation.

Configuration options: [Enabled] [Disabled]

4.6 Boot menu

The Boot menu items allow you to change the system boot options. Select an item then press <Enter> to display the sub-menu.

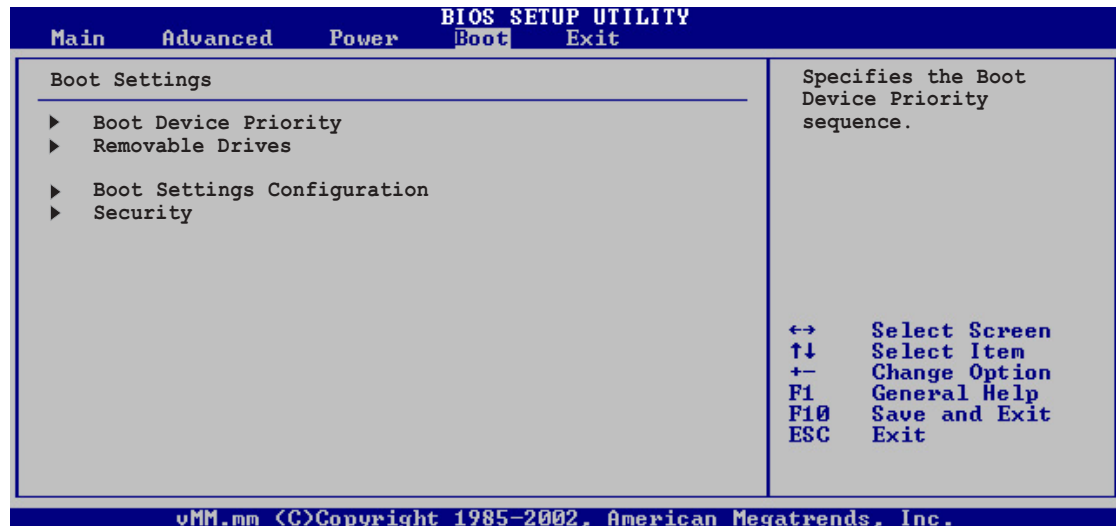

4.6.1 Boot Device Priority

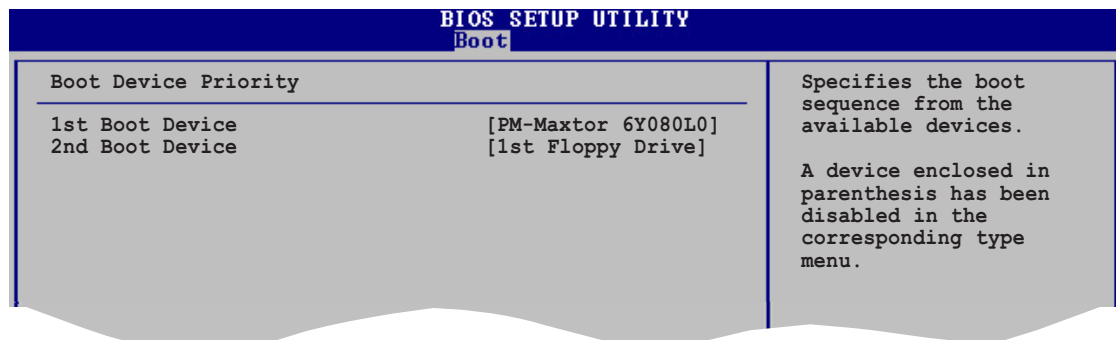

1st ~ xxth Boot Device [1st Floppy Drive]

These items specify the boot device priority sequence from the available devices. The number of device items that appear on the screen depends on the the number of devices installed in the system.

Configuration options: [xxxxx Drive] [Disabled]

4.6.2 Removable Drives

BIOS SETUP UTILITY	
[Boot]	
Removable Drives	
1st Drive [1st Floppy Drive]	Specifies the boot sequence from the available devices.

1st ~ xxth Drive [1st Floppy Drive]

These items specify the boot sequence from the available removable drives. The number of drives that appear on the screen depends on the the number of devices installed in the system. Configuration options: [xxxxx Drive] [Disabled]

4.6.3 Boot Settings Configuration

BIOS SETUP UTILITY	
[Boot]	
Boot Settings Configuration	
Quick Boot [Enabled]	Allows BIOS to skip certain tests while booting. This will decrease the time needed to boot the system. ↔ Select Screen
Full Screen Logo [Enabled]	
Add On ROM Display Mode [Force BIOS]	
Bootup Num-Lock [On]	
PS/2 Mouse Support [Auto]	
Typematic Rate [Fast]	
Boot to OS/2 [No]	
Wait for 'F1' If Error [Enabled]	
Hit 'DEL' Message Display [Enabled]	
Interrupt 19 Capture [Disabled]	

Quick Boot [Enabled]

Enabling this item allows the BIOS to skip some power on self tests (POST) while booting to decrease the time needed to boot the system. When set to [Disabled], BIOS performs all the POST items.

Configuration options: [Disabled] [Enabled]

Full Screen Logo [Enabled]

This allows you to enable or disable the full screen logo display feature.

Configuration options: [Disabled] [Enabled]



Make sure that the Full Screen Logo item is set to [Enabled] if you want to use the ASUS MyLogo2™ feature.

Add On ROM Display Mode [Force BIOS]

Sets the display mode for option ROM.

Configuration options: [Force BIOS] [Keep Current]

Bootup Num-Lock [On]

Allows you to select the power-on state for the NumLock.

Configuration options: [Off] [On]

PS/2 Mouse Support [Auto]

Allows you to enable or disable support for PS/2 mouse.

Configuration options: [Disabled] [Enabled] [Auto]

Typematic Rate [Fast]

Allows you to select the keyboard typematic rate.

Configuration options: [Slow] [Fast]

Boot to OS/2 [No]

Allows you to specify the OS/2 compatibility mode.

Configuration options: [No] [Yes]

Wait for 'F1' If Error [Enabled]

When set to Enabled, the system waits for F1 key to be pressed when error occurs. Configuration options: [Disabled] [Enabled]

Hit 'DEL' Message Display [Enabled]

When set to Enabled, the system displays the message "Press DEL to run Setup" during POST. Configuration options: [Disabled] [Enabled]

Interrupt 19 Capture [Disabled]

When set to [Enabled], this function allows the option ROMs to trap Interrupt 19. Configuration options: [Disabled] [Enabled]

4.6.4 Security

The Security menu items allow you to change the system security settings. Select an item then press <Enter> to display the configuration options.

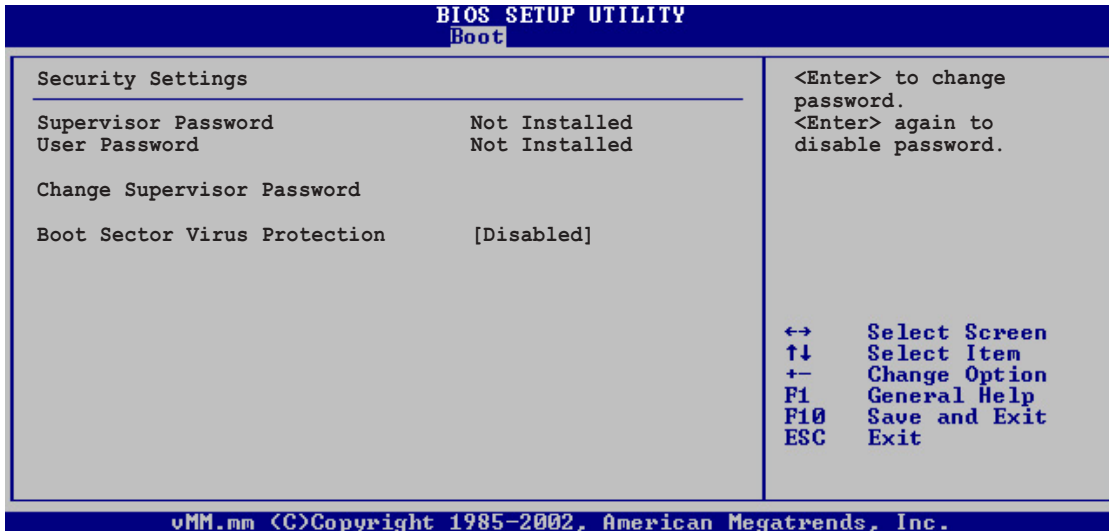

Change Supervisor Password

Select this item to set or change the supervisor password. The Supervisor Password item on top of the screen shows the default **Not Installed**. After you have set a password, this item shows **Installed**.

To set a **Supervisor Password**:

1. Select the Change Supervisor Password item and press <Enter>.
2. On the password box that appears, type a password composed of letters and/or numbers, then press Enter. Your password should have at least six characters.
3. Confirm the password when prompted.

The message "Password Installed" appears after you have successfully set your password.

The Supervisor Password item now shows **Installed**.

To change the supervisor password, follow the same steps as in setting a user password.

To clear the supervisor password, select the Change Supervisor Password then press <Enter>. The message "Password Uninstalled" appears.



If you forget your BIOS password, you can clear it by erasing the CMOS Real Time Clock (RTC) RAM. Refer to section "3.3 Jumper" for instructions on erasing the RTC RAM.

After you have set a supervisor password, the other items appear to allow you to change other security settings.

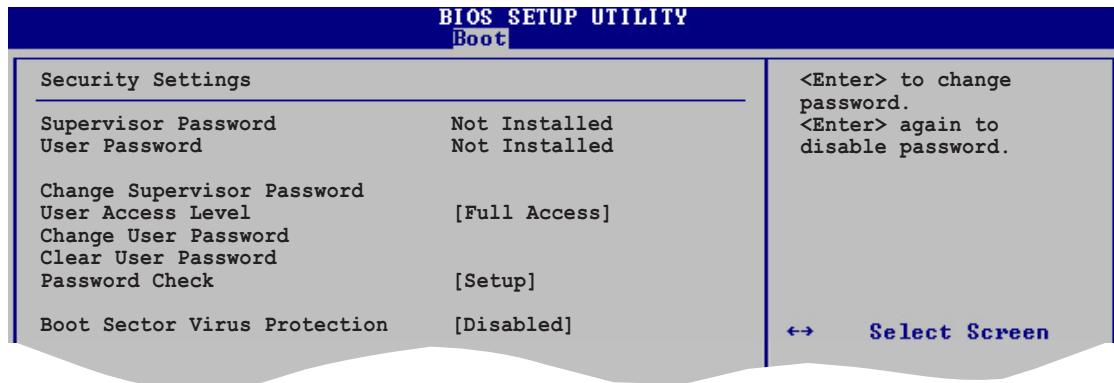

User Access Level (Full Access]

This item allows you to select the access restriction to the Setup items. Configuration options: [No Access] [View Only] [Limited] [Full Access]

No Access prevents user access to the Setup utility.

View Only allows access but does not allow change to any field.

Limited allows change to only selected fields, such as Date and Time.

Full Access allows viewing and changing all the fields in the Setup utility.

Change User Password

Select this item to set or change the user password. The User Password item on top of the screen shows the default **Not Installed**. After you have set a password, this item shows **Installed**.

To set a **User Password**:

1. Select the Change User Password item and press Enter.
2. On the password box that appears, type a password composed of letters and/or numbers, then press Enter. Your password should have at least six characters.
3. Confirm the password when prompted.

The message "**Password Installed**" appears after you have successfully set your password. The User Password item now shows **Installed**.

To change the user password, follow the same steps as in setting a user password.

Clear User Password

Select this item if you want to clear the user password.

Password Check [Setup]

When set to [Setup], BIOS checks for user password when accessing the Setup utility. When set to [Always], BIOS checks for user password both when accessing Setup and booting the system.

Configuration options: [Setup] [Always]

Boot Sector Virus Protection [Disabled]

Allows you to enable or disable the boot sector virus protection.

Configuration options: [Disabled] [Enabled]

4.7 Exit menu

The Exit menu items allow you to load the optimal or failsafe default values for the BIOS items, and save or discard your changes to the BIOS items.

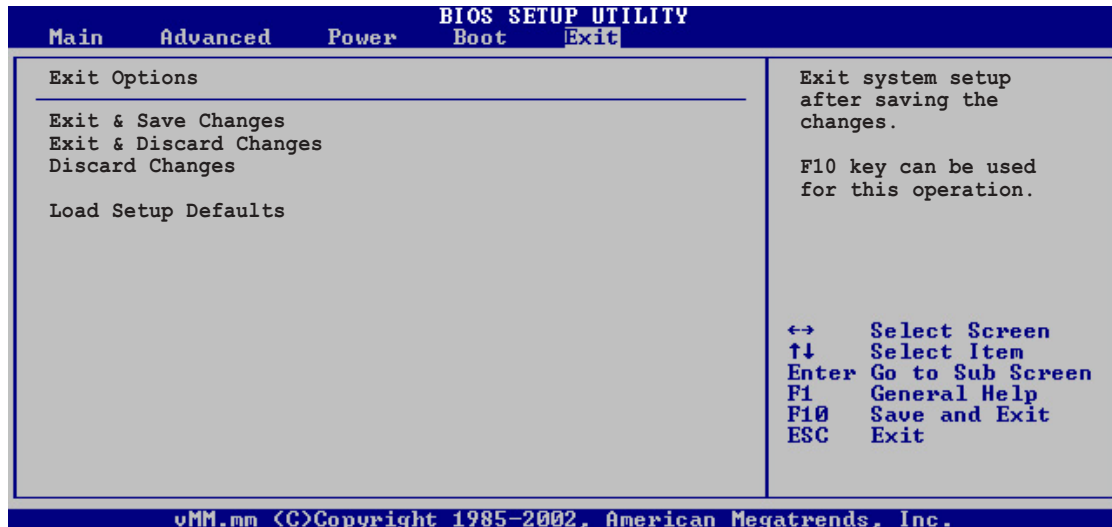

Pressing <Esc> does not immediately exit this menu. Select one of the options from this menu or <F10> from the legend bar to exit.

Exit & Save Changes

Once you are finished making your selections, choose this option from the Exit menu to ensure the values you selected are saved to the CMOS RAM. The CMOS RAM is sustained by an onboard backup battery and stays on even when the PC is turned off. When you select this option, a confirmation window appears. Select [Yes] to save changes and exit.



If you attempt to exit the Setup program without saving your changes, the program prompts you with a message asking if you want to save your changes before exiting. Pressing <Enter> saves the changes while exiting.

Exit & Discard Changes

Select this option only if you do not want to save the changes that you made to the Setup program. If you made changes to fields other than system date, system time, and password, the BIOS asks for a confirmation before exiting.

Discard Changes

This option allows you to discard the selections you made and restore the previously saved values. After selecting this option, a confirmation appears. Select [Yes] to discard any changes and load the previously saved values.

Load Setup Defaults

This option allows you to load the default values for each of the parameters on the Setup menus. When you select this option or if you press <F5>, a confirmation window appears. Select [Yes] to load default values. Select Exit Saving Changes or make other changes before saving the values to the non-volatile RAM.

Chapter 5

This chapter helps you power up the system and install drivers and utilities from the support CD.

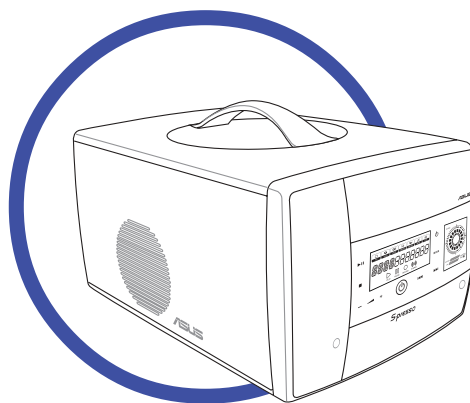

ASUS S-presso barebone system

Starting up



For model S1-P111 with Instant On feature, make sure you have installed Instant On **before** proceeding to this section. Refer to Chapter 1 of the **Software Information** guide for instructions on installing Instant On.

5.1 Installing an operating system

The S-presso system supports Windows® 2000/XP operating systems (OS). Always install the latest OS version and corresponding updates so you can maximize the features of your hardware.

5.2 Powering up

Press the system power button (⏻) to enter the S-presso operating system (OS). Touch the Instant On power sensor (⏻) to turn on the S-presso Instant On feature. See Chapter 1 of the **Software Information** guide for details on the Instant On feature.

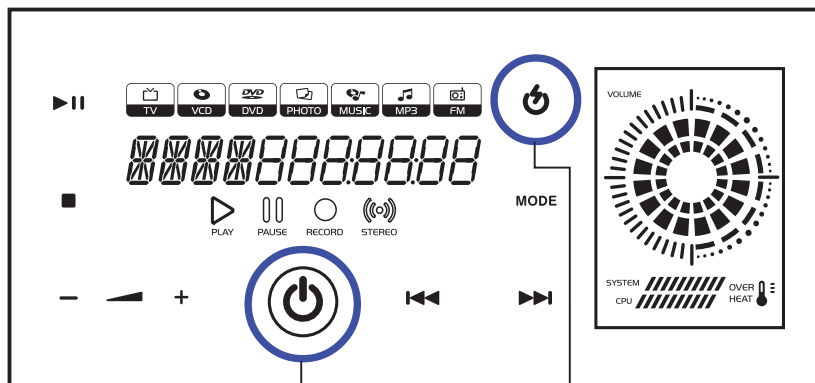

System power button

Instant On power sensor

5.3 Support CD information

The support CD that came with the S-presso system contains useful software and several utility drivers that enhance the motherboard features.



- Screen display and driver options may not be the same for other operating system versions.
- The contents of the support CD are subject to change at any time without notice. Visit the ASUS website for updates.

5.3.1 Running the support CD

To begin using the support CD, place the CD into your optical drive. The CD automatically displays the **Drivers** menu if Autorun is enabled in your computer.

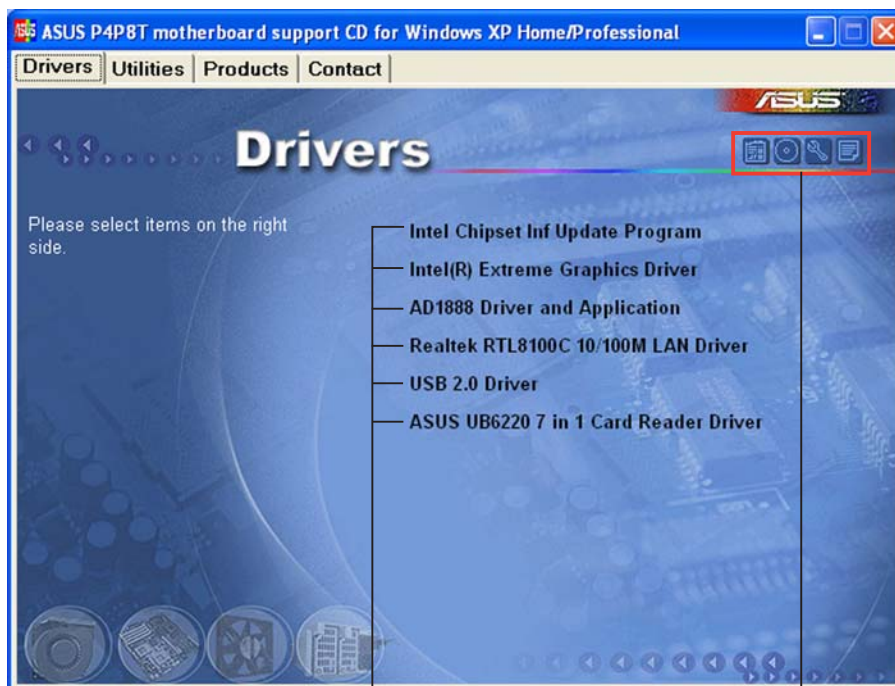

Click an item to install

Click an icon to display other information



If **Autorun** is NOT enabled in your computer, browse the contents of the support CD to locate the file **ASSETUP.EXE** from the BIN folder. Double-click the **ASSETUP.EXE** to run the CD.

5.3.2 Drivers menu

The drivers menu shows the available device drivers if the system detects installed devices. Install the necessary drivers to activate the devices.

Intel Chipset Inf Update Program

This item installs the Intel® Chipset INF Update Program. This driver enables Plug-n-Play INF support for the Intel® chipset components on the motherboard. When installed to the target system, this driver provides the method for configuring the chipset components.

You can install this utility using three different modes: interactive, silent, or unattended preload. Installing the driver in interactive mode requires user input during installation. User input is not required when installing the driver in silent or unattended preload modes. Refer to the online help or readme file that came with the utility for details

Intel(R) Extreme Graphics Driver

Installs the Intel® Extreme Graphics Driver.

ADI1888 Driver and Application

Installs the ADI1888 audio driver and the SoundMAX® application. |See page 5-14 for details.

Realtek RTL8100C 10/100M LAN Driver

Installs the Realtek® RTL8100C 10/100M LAN Driver.

USB 2.0 Driver

Installs the USB 2.0 driver.

ASUS UB6220 7 in 1 Card Reader Driver

Installs the ASUS UB6220 7-in-1 Card Reader driver.

5.3.3 Utilities menu

The Utilities menu shows the applications and other software that the motherboard supports.

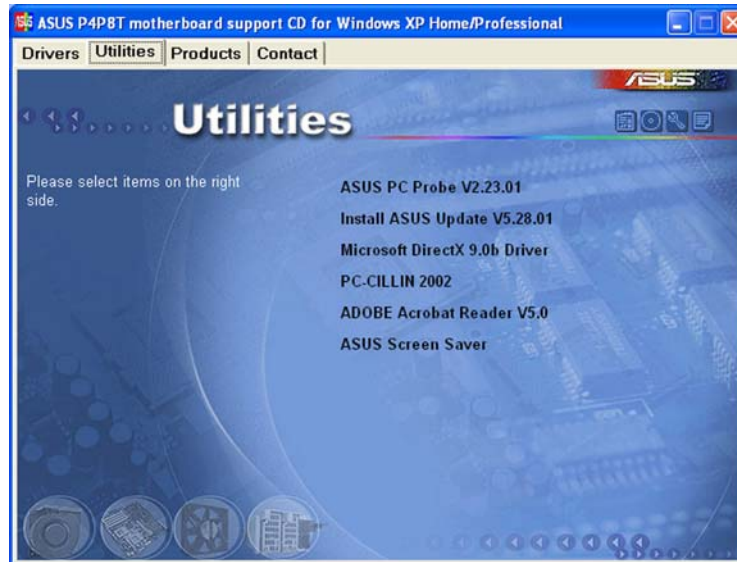

ASUS PC Probe

This utility continuously monitors vital system information such as fan rotations, CPU temperature, and system voltages, and alerts you on any detected problems. This utility helps you keep your computer in a healthy operating condition. See page 5-10 for details.

ASUS Update

Installs the ASUS Update that allows you to update the motherboard BIOS in Windows® environment. This utility requires an Internet connection either through a network or an Internet Service Provider (ISP). See page 5-8 for details.

PC-CILLIN 2002

Installs the PC-cillin 2002 anti-virus program. View the PC-cillin online help for detailed information.

Adobe® Acrobat Reader®

Installs the Adobe® Acrobat Reader®. The Acrobat Reader® software is for viewing files saved in Portable Document Format (PDF).

ASUS Screensaver

Installs the ASUS screensaver.

5.3.4 ASUS contact information

Click the Contact tab to display the ASUS contact information.

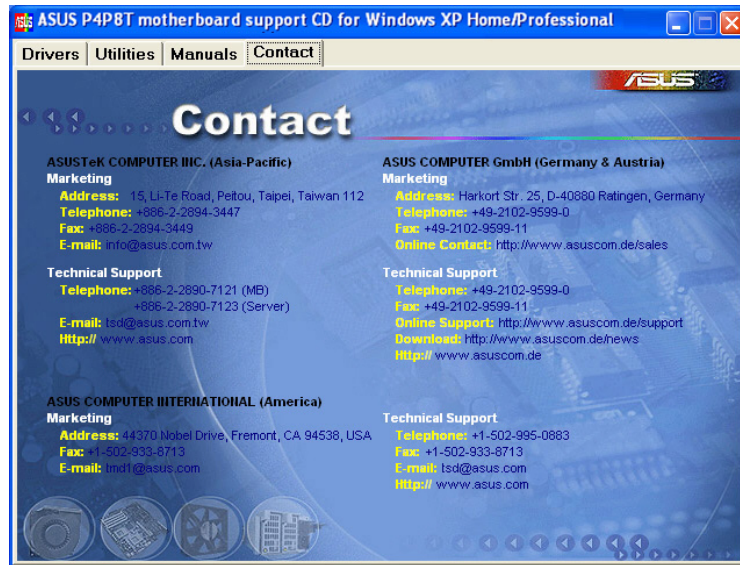

5.3.5 Other information

The icons on the top right side of the screen give additional information on the motherboard and the contents of the support CD. Click an icon to display the specified information.

Motherboard info

Displays the general specifications of the motherboard.

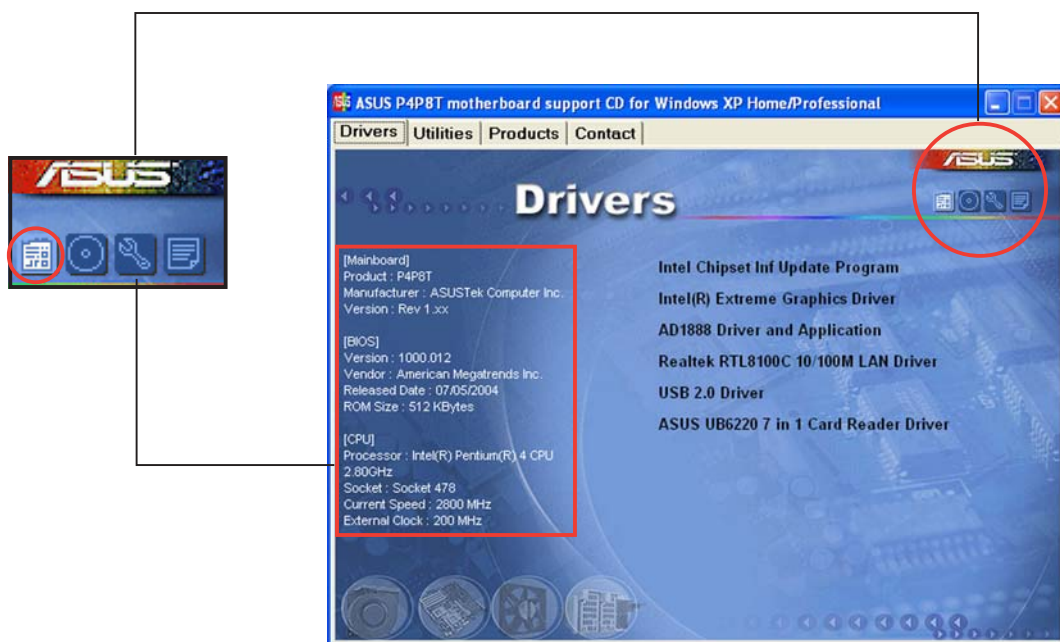

Browse this CD

Displays the support CD contents in graphical format.

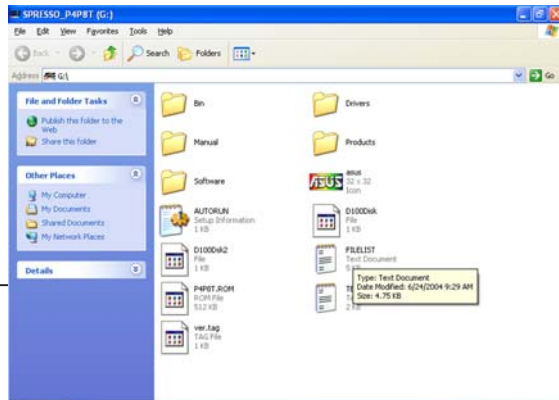
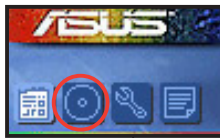

Technical support form

Displays the ASUS Technical Support Request Form that you have to fill out when requesting technical support.

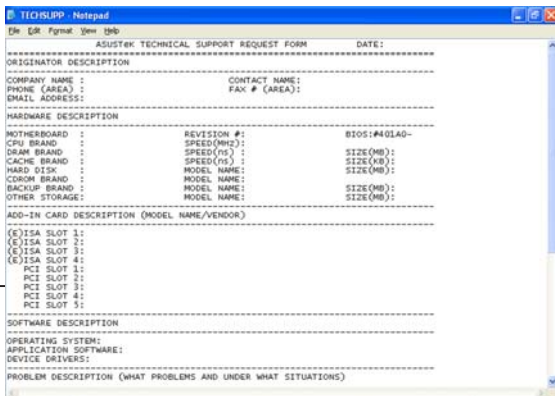
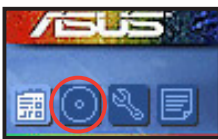

Filelist

Displays the contents of the support CD and a brief description of each in text format.

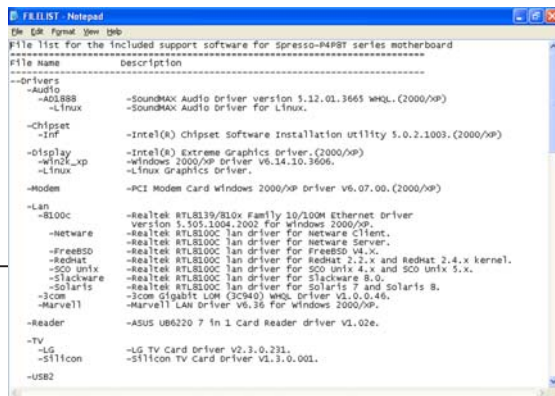
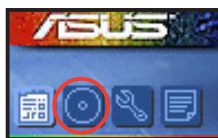

5.4 Software information

Most of the applications in the support CD have wizards that will conveniently guide you through the installation. View the online help or readme file that came with the software for more information.

5.4.1 ASUS Update

The ASUS Update is a utility that allows you to update the motherboard BIOS and drivers. This utility requires an Internet connection either through a network or an Internet Service Provider (ISP).

Follow these steps to use the ASUS Update.

1. Launch the utility from your Windows Start menu:
Programs/AsusUpdate Vx.xx.xx/AsusUpdate

The ASUS Update initial screen appears.

2. Select your desired update method, then click **Next**.

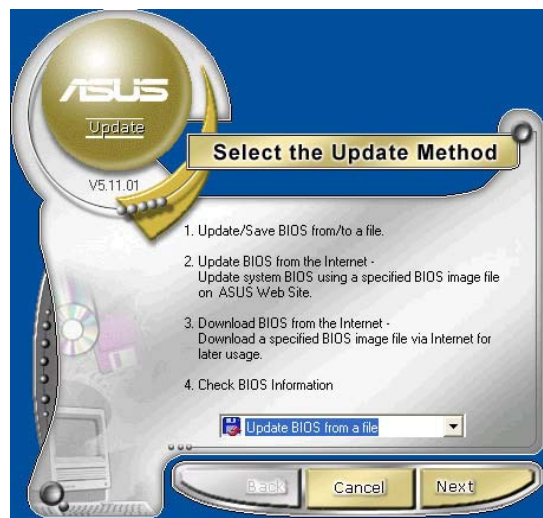

3. If you selected updating/downloading from the Internet, select the ASUS FTP site nearest you to avoid network traffic, or choose Auto Select. Click **Next**.

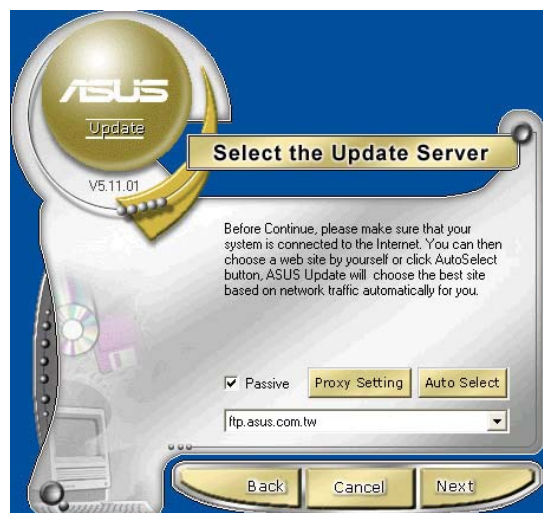

- From the FTP site, select the BIOS version that you wish to download. Click **Next**.

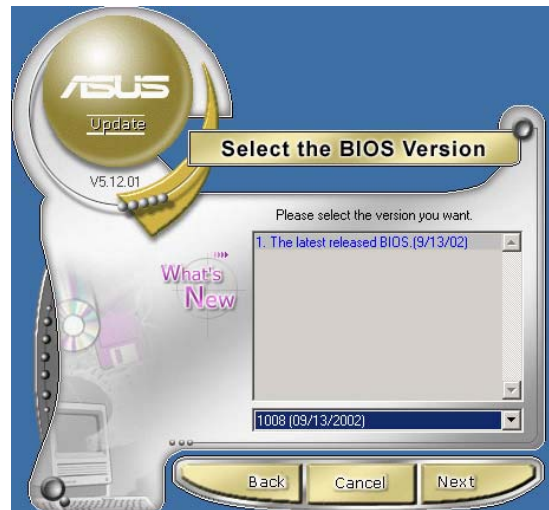

- The BIOS ROM information is displayed. Click Flash to update the BIOS.

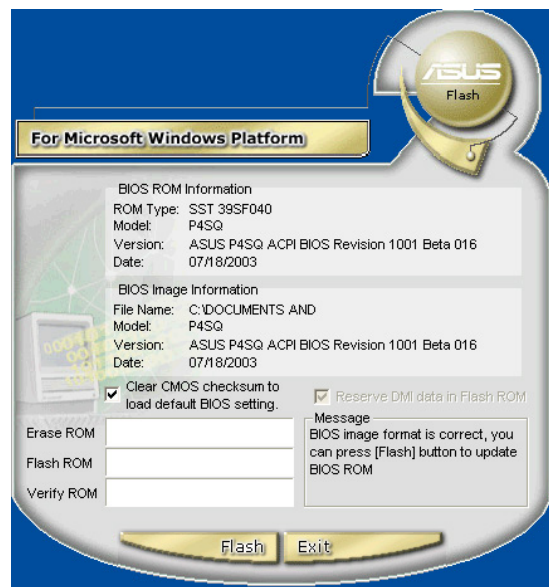

If you selected the option to update the BIOS from a file, a window pops up prompting you to locate the file. Select the file, click Save, then follow the screen instructions to complete the update process.

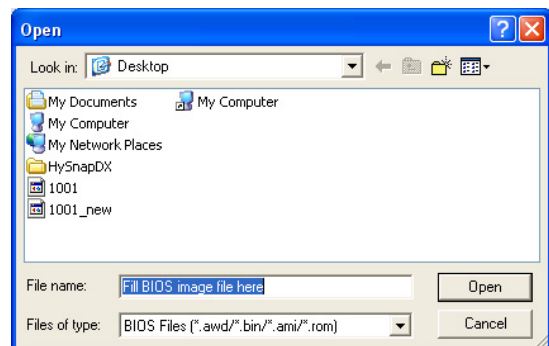

5.4.2 ASUS PC Probe

ASUS PC Probe is a monitoring utility that continuously keeps track of vital system information such as fan rotations, voltages, and temperatures. This utility also allows you to check other information about your computer, including hard disk space, memory usage, and CPU type, CPU speed, and internal/external frequencies through the DMI Explorer.

Starting ASUS PC Probe

When ASUS PC Probe starts, a splash screen appears allowing you to select whether to show the screen again when you open PC Probe or not. To bypass this startup screen, clear the **Show up in next execution** check box.

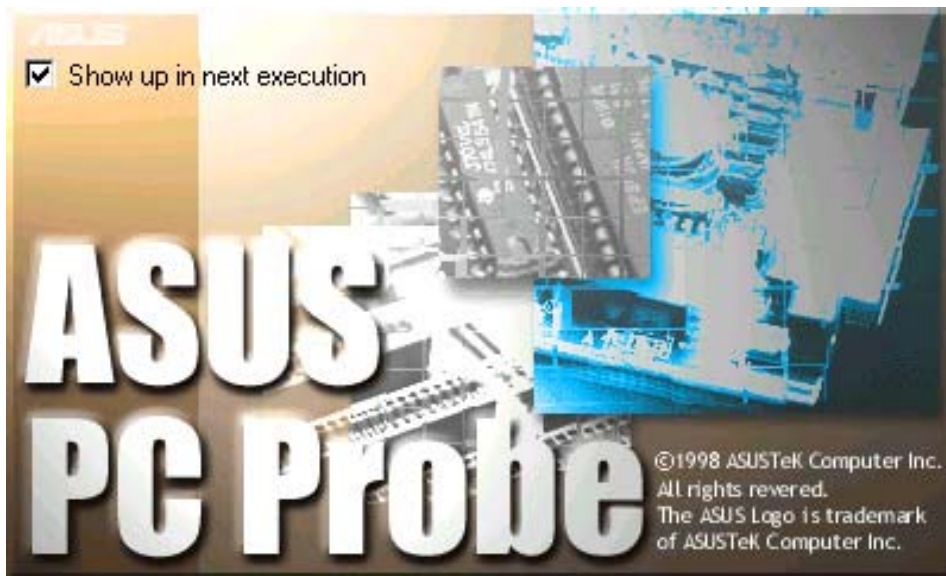

To launch **ASUS PC Probe**, click the Windows **Start** button, point to **Programs**, and then **ASUS Utility**, and then click **Probe Vx.xx**.

The PC Probe icon  in the taskbar system tray indicates that ASUS PC Probe is running. Clicking the icon allows you to see the status of your PC.

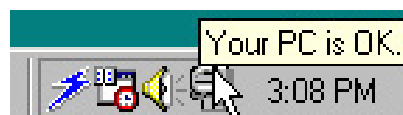

Using ASUS PC Probe

Monitoring tab

Monitor Summary

Shows a summary of the items being monitored.

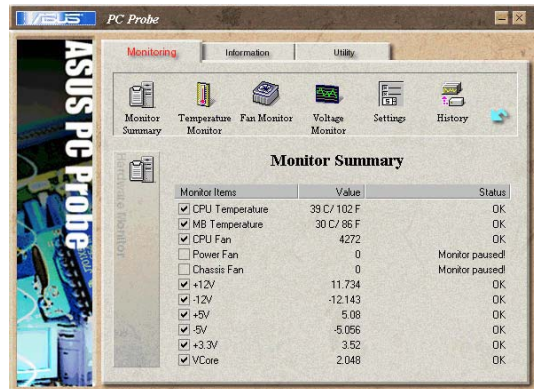

Temperature Monitor

Shows the system temperature (for supported processors only).

Temperature Warning threshold adjustment

(Move the slider up to increase the threshold level or down to decrease the threshold level)

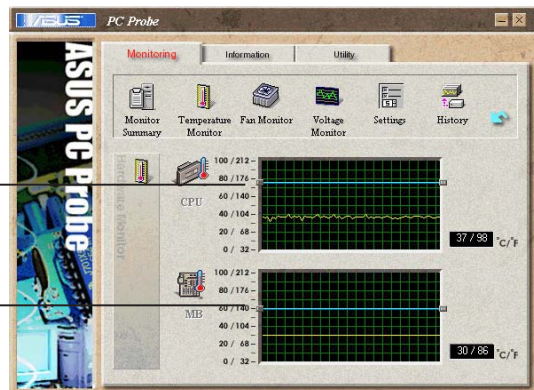

Fan Monitor

Shows the system's fan rotations.

Fan Warning threshold adjustment

(Move the slider up to increase the threshold level or down to decrease the threshold level)

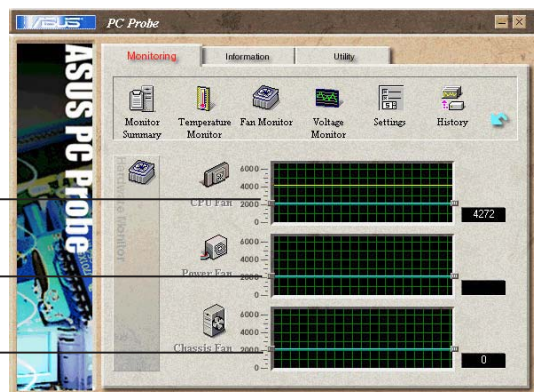

Voltage Monitor

Shows the system voltages.

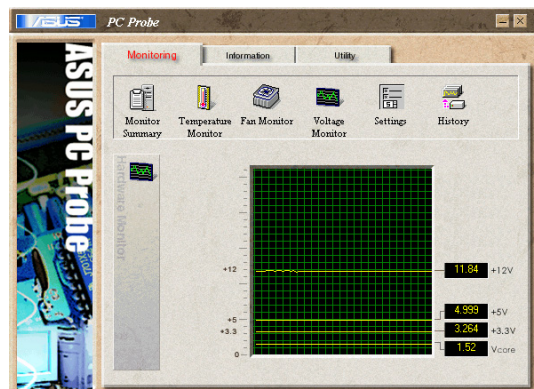

Settings

Lets you set threshold levels and polling intervals or refresh times of the system temperature, fan rotation, and voltages.

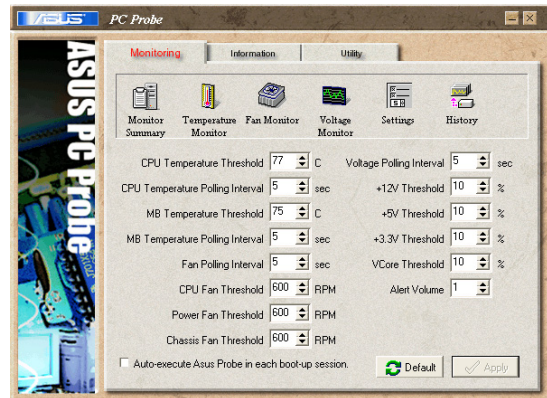

History

Lets you record the monitoring activity of a certain component of the system for future reference.

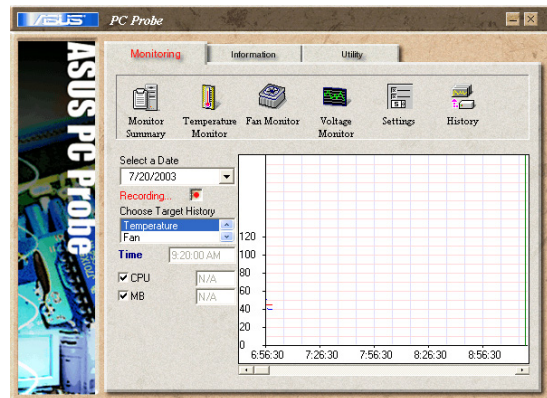

Information tab

Hard Drive

Shows the used and free space of the system's hard disk drive and the file allocation table or file system used.

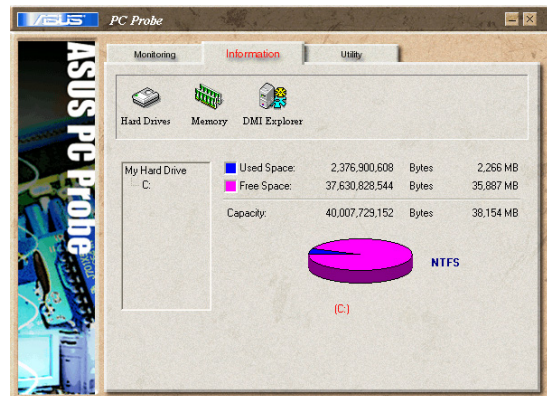

Memory

Shows the system memory load, memory usage, and paging file usage.

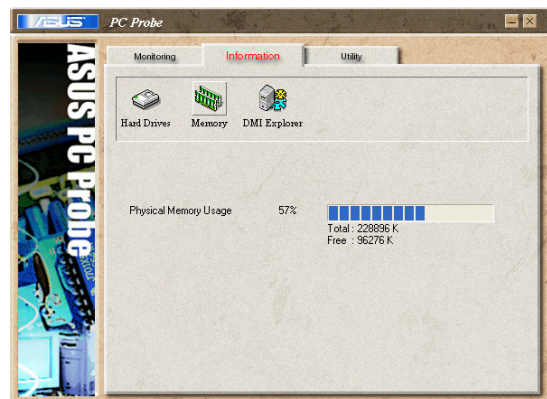

DMI Explorer

Shows information pertinent to the system, such as CPU type, CPU speed, and internal/external frequencies, and memory size.



Utility tab

Utility

Lets you run programs outside of the ASUS Probe modules. To run a program, click **Execute Program**. **NOTE:** This feature is currently unavailable.

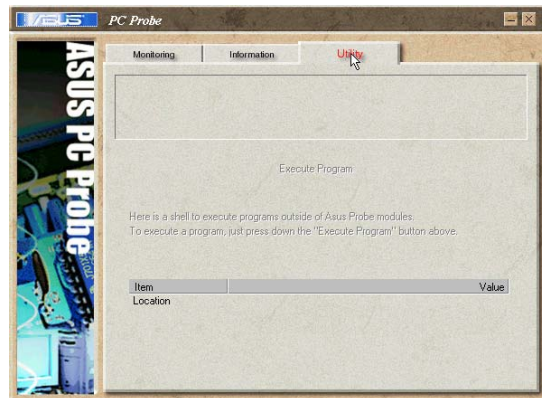

ASUS PC Probe Task Bar Icon

Right clicking the PC Probe icon brings up a menu to open or exit ASUS PC Probe and pause or resume all system monitoring.



When the ASUS PC Probe senses a problem with your PC, portions of the ASUS PC Probe icon change to red, the PC speaker beeps, and the ASUS PC Probe monitor appears.



5.4.3 Multi-channel audio feature

The ADI AD1888 audio CODEC provides 6-channel audio capability. Install the **SoundMAX® Audio Driver and Application** from the support CD that came with the motherboard package to activate the 6-channel audio feature.



You must use 4-channel or 6-channel speakers for this setup.

Setting to multi-channel audio

After installing the audio driver, follow these instructions to adjust the audio settings and avail the onboard 6-channel audio feature.

1. From the taskbar, double-click on the **SoundMAX Digital Integrated Audio** icon to display the **SoundMAX Control Panel**.
2. The **Listening Environment** tab allows you to set to multi-channel speakers, enable or disable the **Virtual Theater Surround**, and select **Acoustic Environments** and **Virtual Ear**.
3. The default setting is **Stereo Speakers** (2-channel). To set to a 6-channel speaker system, click the arrow under **Speaker Setup** to display a list of options.
4. Select the option **Surround Sound Speakers (5.1 Surround)**.
5. Click the **Apply** button.
6. Click the **Test** button to display the **Test Listening Environment** window.
7. Select the audio test path from the drop-down menu.

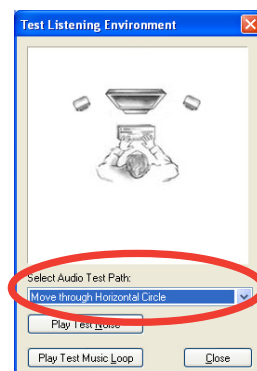
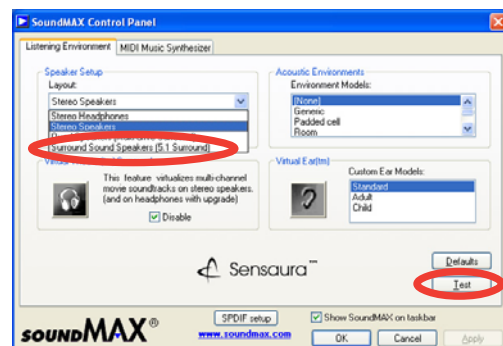
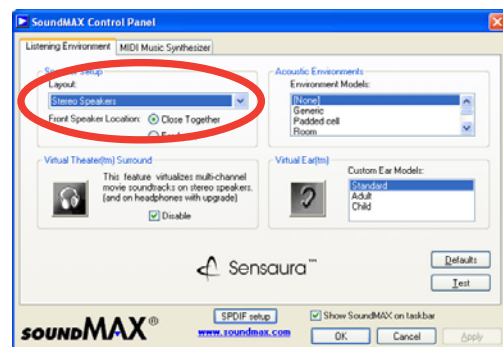

8. After selecting an option, test your setting by clicking the **Play Test Noise** button. While testing, you will see a black circle moving on the screen indicating the audio path.

The **Play Test Noise** button becomes **Stop Playing** button. Click this button at any time to stop playing.

9. Click the **Close** button when done.

Audio path indicator

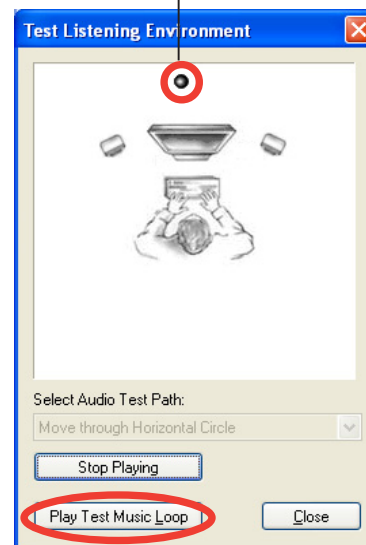

10. The **MIDI Music Synthesizer** tab allows you to select a setting for the MIDI.

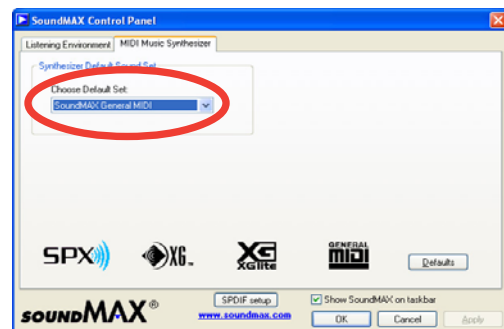

11. Click the **Synthesizer Default Set** drop-down menu to display a list of options. Choose the desired setting.
12. Click **Apply**, then click **OK** when finished.
13. Reboot the computer.

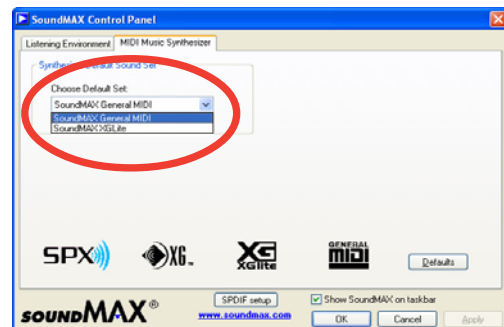

Adjusting the volume settings

1. After rebooting the system, click on the volume control icon on the Windows® taskbar to display the **Volume Control** window.

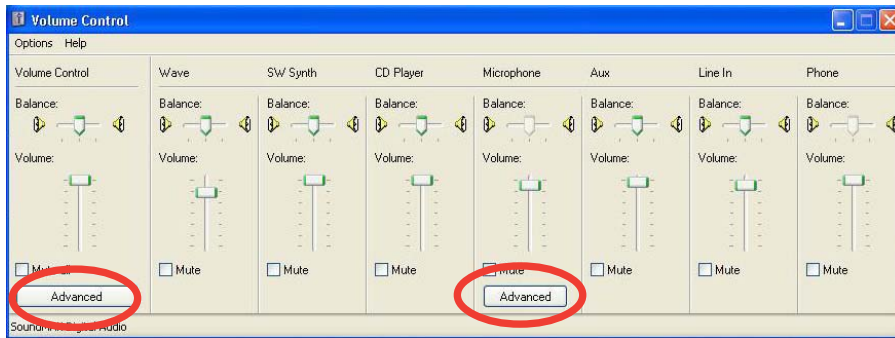

2. Click the Volume Control **Advanced** button. The **Advanced Controls for Volume Control** window appears.

To achieve 6-channel audio capability when playing DVDs, check the boxes opposite **AC3 SPDIF** and **PCM SPDIF**. Click **Close**.

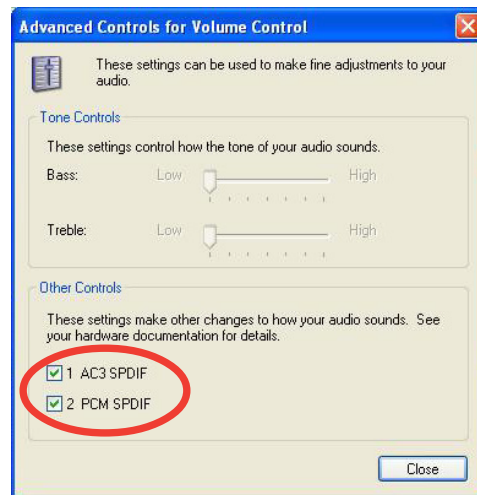

Adjusting the microphone settings

1. Click on the Microphone **Advanced** button to display the **Advanced Controls for Microphone** window.
2. Check the box opposite **Mic2 Select** to enable the front panel microphone.
3. Click **Close** for the new settings to take effect.

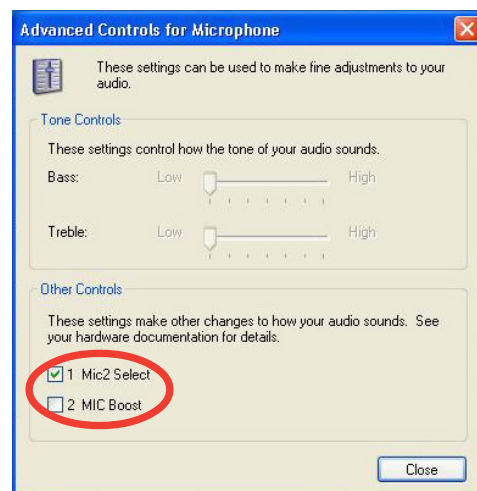

The rear panel Mic port (pink) is automatically disabled when you enable the front panel Mic port. Only one Mic port works at a time.